



**Sustainable Transport:  
A Sourcebook for Policy-makers in Developing Cities  
Module 2a**

## **Land Use Planning and Urban Transport**

– revised September 2004 –



Deutsche Gesellschaft für  
Technische Zusammenarbeit (GTZ) GmbH

## OVERVIEW OF THE SOURCEBOOK

### Sustainable Transport: A Sourcebook for Policy-Makers in Developing Cities

#### What is the Sourcebook?

This *Sourcebook* on Sustainable Urban Transport addresses the key areas of a sustainable transport policy framework for a developing city. The *Sourcebook* consists of 20 modules.

#### Who is it for?

The *Sourcebook* is intended for policy-makers in developing cities, and their advisors. This target audience is reflected in the content, which provides policy tools appropriate for application in a range of developing cities.

#### How is it supposed to be used?

The *Sourcebook* can be used in a number of ways. It should be kept in one location, and the different modules provided to officials involved in urban transport. The *Sourcebook* can be easily adapted to fit a formal short course training event, or can serve as a guide for developing a curriculum or other training program in the area of urban transport. GTZ is meanwhile elaborating training packages for selected modules, being available from June 2004.

#### What are some of the key features?

The key features of the *Sourcebook* include:

- A practical orientation, focusing on best practices in planning and regulation and, where possible, successful experience in developing cities.
- Contributors are leading experts in their fields.
- An attractive and easy-to-read, color layout.
- Non-technical language (to the extent possible), with technical terms explained.
- Updates via the Internet.

#### How do I get a copy?

Please visit <http://www.sutp-asia.org> or <http://www.gtz.de/transport> for details on how to order a copy. The *Sourcebook* is not sold for profit. Any charges imposed are only to cover the cost of printing and distribution. You may also order via [transport@gtz.de](mailto:transport@gtz.de).

#### Comments or feedback?

We would welcome any of your comments or suggestions, on any aspect of the *Sourcebook*, by e-mail to [transport@gtz.de](mailto:transport@gtz.de), or by surface mail to:  
Manfred Breithaupt  
GTZ, Division 44  
P. O. Box 5180  
D - 65726 Eschborn  
Germany

## Modules and contributors

*Sourcebook Overview and Cross-cutting Issues of Urban Transport* (GTZ)

### Institutional and policy orientation

- 1a. *The Role of Transport in Urban Development Policy* (Enrique Peñalosa)
- 1b. *Urban Transport Institutions* (Richard Meakin)
- 1c. *Private Sector Participation in Transport Infrastructure Provision*, (Christopher Zegras, MIT)
- 1d. *Economic Instruments* (Manfred Breithaupt, GTZ)
- 1e. *Raising Public Awareness about Sustainable Urban Transport* (Karl Fjellstrom, GTZ)

### Land use planning and demand management

- 2a. *Land Use Planning and Urban Transport* (Rudolf Petersen, Wuppertal Institute)
- 2b. *Mobility Management* (Todd Litman, VTPI)

### Transit, walking and cycling

- 3a. *Mass Transit Options* (Lloyd Wright, University College London; Karl Fjellstrom, GTZ)
- 3b. *Bus Rapid Transit* (Lloyd Wright, University College London)
- 3c. *Bus Regulation & Planning* (Richard Meakin)
- 3d. *Preserving and Expanding the Role of Non-motorised Transport* (Walter Hook, ITDP)

### Vehicles and fuels

- 4a. *Cleaner Fuels and Vehicle Technologies* (Michael Walsh; Reinhard Kolke, Umweltbundesamt – UBA)
- 4b. *Inspection & Maintenance and Roadworthiness* (Reinhard Kolke, UBA)
- 4c. *Two- and Three-Wheelers* (Jitendra Shah, World Bank; N.V. Iyer, Bajaj Auto)
- 4d. *Natural Gas Vehicles* (MVV InnoTec)

### Environmental and health impacts

- 5a. *Air Quality Management* (Dietrich Schwela, World Health Organisation)
- 5b. *Urban Road Safety* (Jacqueline Lacroix, DVR; David Silcock, GRSP)
- 5c. *Noise and its Abatement* (Civic Exchange Hong Kong; GTZ; UBA)

### Resources

6. *Resources for Policy-makers* (GTZ)

### Further modules and resources

Further modules are anticipated in the areas of *Driver Training*; *Financing Urban Transport*; *Benchmarking*; and *Car Free Days*. Additional resources are being developed, and an Urban Transport Photo CD-ROM is available.

# Land Use Planning and Urban Transport

Findings, interpretations and conclusions expressed in this document are based on information gathered by GTZ and its consultants, partners, and contributors from reliable sources. GTZ does not, however, guarantee the accuracy or completeness of information in this document, and cannot be held responsible for any errors, omissions or losses which emerge from its use.

## About the author

The **Wuppertal Institute for Climate, Environment, and Energy (WI)** works towards overcoming the conflicting requirements of economy and ecology. Increased prosperity combined with a reduction in consumption of natural resources: this is the paradigm for eco-efficient innovation and for a new generation of technology. To help achieve these aims, the WI draws up concrete concepts for realising them in the areas of energy, transport, material flows and climate policy, as well as providing tangible visions for new models of prosperity. Moreover, the WI actively contributes to developing and promoting specific options, policies and measures to mitigate climate change.

Prof. Dr Petersen has been Director of the Transport Division at the Wuppertal Institute since 1991. Prior to that he has worked for the Ministry of Town Development and Traffic in North Rhine-Westphalia, and the Federal Environmental Agency. Since 2001 he has been Honorary Professor at the Faculty of Mechanical Engineering, University of Essen. His working expertise and publication list

covers policy analysis of transport and environment, and vehicle technology. Research projects have spanned the fields of passenger and freight transport, with a focus on environmental aspects. International consultancy experience on transport policy and urban development includes Latin America, Asian as well as Arabic countries. The author thanks Dipl.-Ing. Carolin Schäfer for support in research and editing.

### Author:

Rudolf Petersen (Wuppertal Institute)  
With additional contribution by Carolin Schäfer (Wuppertal Institute)

### Editor:

Deutsche Gesellschaft für  
Technische Zusammenarbeit (GTZ) GmbH  
P. O. Box 5180  
D - 65726 Eschborn, Germany  
<http://www.gtz.de>

Division 44, Environment and Infrastructure  
Sector Project "Transport Policy Advice"

Commissioned by  
Bundesministerium für wirtschaftliche  
Zusammenarbeit und Entwicklung (BMZ)  
Friedrich-Ebert-Allee 40  
D - 53113 Bonn, Germany  
<http://www.bmz.de>

### Manager:

Manfred Breithaupt

### Editorial Board:

Manfred Breithaupt, Karl Fjellstrom\*, Stefan Opitz,  
Jan Schwaab

*\* We would like to acknowledge the role of Karl Fjellstrom for critical review and appraisal of all contributed articles, identifying and coordinating with contributors, and other contributions concerning all aspects of the sourcebook preparation as well as for editorial and organisational supervision during the entire process of the sourcebook's development, from its initial conception until the final product.*

### Cover photo:

Karl Fjellstrom  
Bicycle parking and land use densification around  
a mass rapid transit system station in Shanghai,  
China, Jan. 2002

### Layout:

Klaus Neumann, SDS, G.C.

### Print:

TZ Verlagsgesellschaft mbH  
Bruchwiesenweg 19,  
D - 64380 Roßdorf, Germany

Eschborn 2002 (revised September 2004)



<b>1. The nature of the problems</b>	<b>1</b>	<b>8. How to organise land use</b>	<b>23</b>
1.1 Land use for transport purposes	1	8.1 Legal and organisational set-up	23
1.2 Interaction between land use patterns, transport and the environment	2	8.2 Land use planning in practice	25
1.3 Managing conflicting demands for urban space	4	8.3 Transport provisions in land use plans	26
1.4 Design and implementation of land use plans	4	Pedestrians	26
		Cyclists	27
		Public transport access	27
		Quality of public transport	27
		Private motor vehicles	28
		Parking policy	28
<b>2. Mobility and transport in international comparison</b>	<b>5</b>	<b>9. Land use planning for reduced travel demand</b>	<b>29</b>
2.1 Results of international surveys	5	9.1 Basic principles	29
2.2 Urban density and modal choice	6	9.2 Shaping urban land use development for sustainable transport	30
		Dutch ABC-Planning	31
		9.3 Regional development for sustainable transport	35
<b>3. Impact of land use on urban transport at different scales</b>	<b>8</b>	<b>10. A checklist for land use and transport plans</b>	<b>38</b>
3.1 Property, building and site level; street characteristics	8	10.1 New developments	38
3.2 Blocks, residential areas, city neighbourhoods	9	10.2 Public transport and land use	38
3.3 Municipal level: urban development and transport	11	10.3 Urban development	38
		10.4 Motorised private traffic	39
		10.5 Freight transport	39
<b>4. Urban growth patterns</b>	<b>13</b>	<b>11. Resources</b>	<b>39</b>
4.1 Simplified schemes	13	11.1 Internet resources	39
4.2 Transport consequences of urban growth	13	11.2 Bibliography	40
<b>5. Growth beyond city borders</b>	<b>14</b>		
<b>6. Trip generation &amp; mode choice related to land use parameters</b>	<b>18</b>		
6.1 Basic principles	18		
6.2 Land use and travel demand in urban areas	18		
<b>7. Influence of transport on spatial development</b>	<b>20</b>		

## 1. The nature of the problems

Urban space has to serve a variety of human needs: housing, working, social interaction, leisure, and mobility of persons and goods. Human beings also need nature within their living areas; green spots for recreation and relaxation. Trees, parks and other greenery helps provide healthy living conditions by cleaning the air of pollutants, absorbing noise, and regulating humidity. Beyond this direct anthropocentric (human-centred) perspective, conservation of natural habitats is necessary for maintaining the functioning of ecosystems of all life on earth.

To create or preserve a livable urban environment, the requirements of these functions have to be balanced against each other. Land use planning serves this process of balancing competing demands on limited urban space. The aim of this module is to provide information and to disseminate experiences in dealing with relationships between land-use structures and transport, and to discuss strategies to support the realisation of more sustainable urban transport by land-use planning. The remainder of this section introduces several of the key aspects which will be considered in more detail in following sections.

### 1.1 Land use for transport purposes

Mobility, especially in the form of motorised transport requires an increasing share of land, both within cities and in rural areas. Cities in highly motorised countries dedicate much of their urban area for roads; typical figures for US, Japanese and European cities being about 15 to 25 percent (Table 1).

**Table 1:**  
**International road space comparison**

CCICED/TWG Urban Transport and Environment Workshop,  
Beijing, April 1999

City	Road Density (km/km <sup>2</sup> )	Road Share of Urban Area (%)	Per Capita Road Area (m <sup>2</sup> )
Chinese megacities	about 4 to 6	about 5 to 7	about 6
Tokyo	18.9	14.9	10.9
London	18.1	24.1	28.0
New York	8	16.6	26.3

Chinese cities, on the contrary, devote only about 5 to 7 percent of their urban area to roads. On a per-capita basis, in Shanghai each person has an average of 6 m<sup>2</sup> of road space while a New Yorker has more than 26 m<sup>2</sup>. Thus, there is a clear difference in available road space per person. In the course of their historic development, societies with high rates of automobile ownership have dedicated increasing shares of urban space for automobile use, and at the same time the population density in these cities has decreased. Is this the direction cities in developing countries have to go to, in order to improve traffic conditions? Planners in developing countries often cite these figures in favour of large road network construction programs. For example, Shanghai has increased the length and the area of paved roads from 1991 to 1997 by 18.6 and 41.6 percent, respectively, expanding especially the network of broad multi-lane and elevated expressways. Per capita road area increased from 4.7 to 6.5 m<sup>2</sup>. In light of the international data, this strategy seems to be logical, but it is highly questionable whether more roads really provide sustainable improvements of the traffic situation. The amount of congestion on main arteries in New York may be even worse than in Shanghai, as it is in Los Angeles or in London. Although published cross-city comparisons of average traffic speeds indicate that the worst situation is in Bangkok, and that some other megacities in Asia also show unsatisfactory traffic flows, this kind of data is not a valid justification for heavy road construction programs. The interaction between transport and land use, and the dynamics of related developments must be considered. Increasing road space may reduce the quality of the urban environment, prevent people from walking and cycling, and force those households who can afford it to move into cleaner and less noisy exurban areas.

North American urban development models in particular do not provide good guidance for densely populated Asian and Latin American regions. The views from Seattle (Photo 1) and Singapore (Photo 2) demonstrate differences of urban forms and land use for transport. While US development created urban wasteland, Asian as well as European cities show high densities and a variety of functions. Photo 1 illustrates a



**Photo 1**  
*Seattle, an example of US-style of urban land use.*

**Photo 2**

*Singapore, an example of Asian/European-style urban land use.*



**Photo 3**  
*Jakarta, main road.*



**Photo 4**  
*Jakarta, small road.*

waste of land resources, and raises questions if this really can be considered a city.

Living and transport conditions vary sharply between developing cities. Transport solutions have to be adapted to local conditions and needs. Photo 3 might just as well have been taken in a US city, in which broad arteries provide space for large cars. But this type of road does not reflect the needs of the people living without a car in a non-car environment (Photo 4). What conclusion can be drawn for the priorities in urban transport policy?

The examples show that simple comparisons of average road space between cities do not in themselves justify additional road infrastructure investments. Car ownership rates differ significantly, as does trip demand and travel distances. A car-oriented life-style is out of reach of most people in developing countries. It is true that private car ownership increases at high rates, as well as the demand for other motorised transport services. This leads to overload of existing roads, congestion, and environmental degradation of urban space. But international experience clearly shows that comprehensive construction programs will not be able to cope with the automobiles' demand for road space.

Planners all around the world know that car-based urban transport is not a sustainable development path – neither with respect to urban functions nor to the environment. Only public transport can assure mobility in large cities. And only by preserving good conditions for walking and cycling it is possible to maintain a satisfactory level of urban quality.

What kind of urban development and what land use planning supports sustainable transport?

## 1.2 Interaction between land use patterns, transport and the environment

The spatial distribution of housing, working, shopping, leisure, and other activities determines average trip distances in urban transport. High population density, as well as a mixture of land uses for various social and economic activities, maintain low distances between origins and destinations of urban trips. Conversely, low-density development and large road areas



increase trip lengths and lead to a higher share of automobile trips.

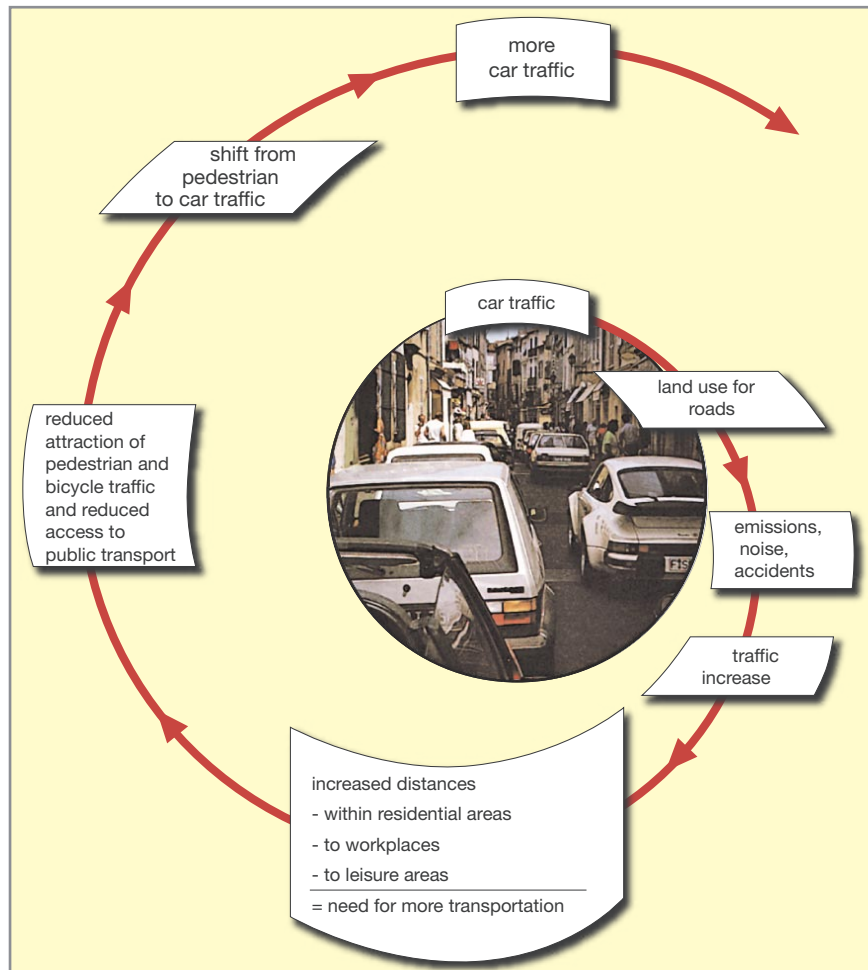
By influencing the spatial structure of locations in the urban environment, land use planning can contribute to a minimisation of kilometres driven, and support a high transit share. Dense and mixed-use development helps to keep walking and cycling attractive. These are the most environmentally friendly transport modes. International comparative studies have indicated that there are close links between population density, motor vehicle use and per-capita energy consumption in the transport sector. Given the high specific emissions per kilometre of motor vehicles in developing countries, the amount of traffic generated by unfavourable spatial structures directly affects air quality.

***“Awareness has risen that the urban planning paradigms of the past need to be changed, and sprawl development needs to be combatted.”***

Further, oil consumption and greenhouse gas emissions will inevitably increase rapidly if transport and land use policies in developing countries follow the kind of spatial transformation which the highly motorised countries have undergone. Figure 1 illustrates the “vicious cycle” of car traffic leading to deteriorated living conditions, heading to suburbanisation and transforming the rural areas into settlements, in which households are dependent on the private car for daily mobility. Increasing car use again follows the traffic spiral, when more roads are built to satisfy car commuters, transforming precious urban land into wasteland as shown in the Seattle photo (Photo 1).

In Europe, Japan and even North America the awareness has risen that the urban planning paradigms of the past need to be changed, and sprawl development needs to be combatted. These insights are based on local experiences, on the observation that congestion and travel-times are ever-increasing, and on the monetary burdens caused for private and public budgets.

Additionally, there are the concerns for the local environment, especially air pollution, noise, groundwater pollution from run-off, loss of soil



**Fig. 1**  
*Traffic and land use interaction (traffic spiral).*  
Wuppertal Institute VE-151e / 95

functions, and loss of biodiversity. And then there are the global concerns with respect to energy resources and greenhouse gas emissions. International climate policy has begun to initiate reduction commitments, which put energy-saving land use policies on the agenda. This has contributed to a critical attitude towards the amount of automobile use – some name it automobile dependency – in Europe and increasingly also in North America. The Kyoto Protocol is just the beginning; future negotiations will require the developing countries to also contribute to greenhouse gas emission reductions.

How can urban land use planning contribute to future responsible mobility with less emissions and energy consumption?

### 1.3 Managing conflicting demands for urban space

Mobility of passengers and of goods is a necessary element of social and economic interaction, forming the basis for progress and welfare by bringing talents and skills together. Division of labour increases productivity, at the cost of increasing transport activities. Migration and population growth cause additional requirements for housing and other land uses. Individualisation of lifestyles and liberalisation of economic activities transform into market forces which compete for scarce urban space. Livable cities need to balance economic, social and environmental requirements against limited space. Besides the competition between housing, shopping, green areas and roads within the traditional urban boundaries, there is the problem of occupying agricultural land by suburbanisation of the various urban functions. Historically, cities have been located in fertile areas where agricultural production could feed the urban population.

---

*“Land-use planning should aim at creating transport-avoiding structures.”*

---

Even if current agricultural production in developing countries may be sufficient in total quantity, loss of resources for nearby food production increases the volume of goods transported over longer distances. Sustainable regional development, on the contrary, would aim at the preservation of agricultural production within close proximity to the urban population. In general, regional manufacturing would provide opportunities for less transport activities, but under current transport price conditions other cost factors dominate the spatial decisions, resulting in larger production and distribution networks.

Although market pressures in most countries work in favour of low-density, space-consuming settlement decisions, land-use planning should aim at creating transport-avoiding structures. Involvement of the public may support this concept, and back the decisions of planners against interest groups.

### 1.4 Design and implementation of land use plans

Land use planning is necessary to assure sound urban and balanced regional development. European and Japanese municipalities have a long-standing tradition in land use planning, and have made some important achievements in maintaining good urban structures. In developing countries there is an increasing awareness of the need for steering urban development in order to avoid unsustainable structures, but institutional capacities and legal provisions for land use planning typically are weak. Without acknowledgement of the interactions between land use planning, urban growth and transport development, no sustainable transport system will emerge, neither with respect to economic nor to social and environmental criteria. Setting priority on road network capacity extensions without a clear vision of spatial development has failed to mitigate congestion everywhere in the world. An increase in traffic capacity, especially on commuter expressways in urban areas, results in a rise of traffic demand that erodes much of the capacity-enhanced traffic improvements.



## 2. Mobility and transport in international comparison

The terms “mobility” and “transport” are often equated. Mobility is reduced to movement, standing simply for the change of location and transport itself. The number of kilometres driven becomes the focus of attention and often becomes the indicator of mobility. As a consequence other options for realising the destinations and purposes that are connected with mobility are not taken into consideration. In fact, a person driving a lower number of kilometres can be more flexible and mobile if he has to drive or even cycle/walk a lower number of kilometres for fulfilling his activities than somebody who depends on a car in order to reach his destinations. In this sense, mobility should be measured in a wider sense relating to “potential access”, rather than simply to “kilometres of movement”.

The following section provides an international comparison of mobility and transport characteristics, and explains the connections between urban density and the choice of transport modes.

## 2.1 Results of international surveys

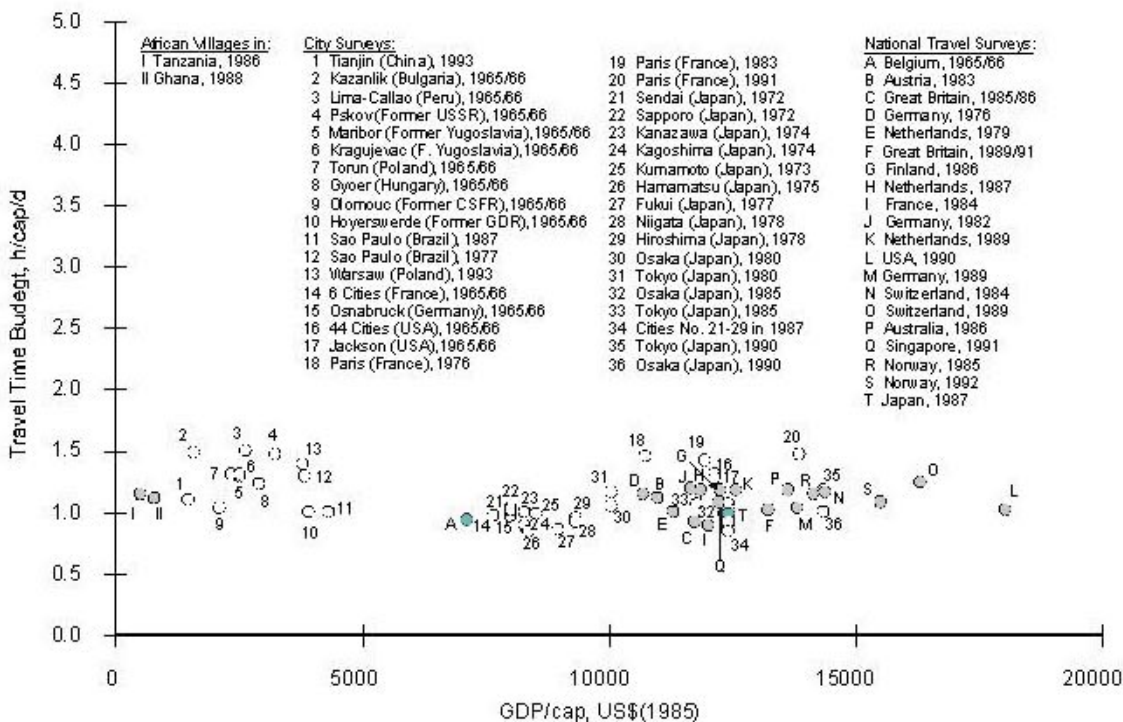
International mobility surveys have indicated that the number of personal trips and the time spent for travel is remarkably constant throughout the world (see Figure 2). This is despite the fact that the conditions for mobility vary considerably between different regions with respect to income and spatial structures. Clearly there are similar time constraints leading – on average – to locational choices and behavioural patterns which limit daily overall travel time to about 60 to 70 minutes.

**Table 2: International urban transport patterns (1990)**

Kenworthy and Laube, et al., 1999

Transport Pattern	Asian cities	European cities	US cities
Car ownership (passenger cars per 1000 persons)	109	392	608
Vehicle ownership (vehicles per 1000 persons)	224	452	749
Specific road length (metres per capita)	1.1	2.4	6.7
Road density (metres of road per urban ha)	122	115	89
NMT (walk+ bicycle+ pedicab, % of work trips)	19	18	5
Role of public transport (% of all passenger km)	48	23	3
Car use per person (km per capita per yr)	1,397	4,519	11,155
Energy use per person (private passenger transport / capita (MJ))	6,969	17,218	55,807

Note: The Asian cities included in this average are Tokyo, Singapore, Hong Kong, Kuala Lumpur, Bangkok, Jakarta, Surabaya and Manila.



**Fig. 2**  
 International travel time survey data.

Schafer and Victor, 2000

The similarity in mobility patterns, however, refers only to travel times, not to travel distances. It is necessary to differentiate between mobility as a basic demand, and transport as a derived demand. Studies about the relations between income, car ownership and transport structures show major differences with respect to distances driven and transport modes used between Asian, European and American cities (see Table 2). Where private cars are available to the average citizen, per-capita kilometres travelled are high, and share of public transport drops. Since according to Figure 2 daily travel time is more or less constant over various regions and societies, this leads to the conclusion that use of faster modes does not bring average time savings but rather enables people to make longer trips in the same time. Conversely, maintaining dense and mixed-use settlement structures would allow people to participate in as many activities while using slower transport modes compared to an automobile society with disperse settlements and an extensive road network.

The differences between Asia, Europe and North America given in Table 2 are significant. But also within the three regions major differences between cities can be found according to the urban development philosophy followed. Several Asian cities took decisions to discourage private car use and improve the public transport system, firstly by upgrading bus systems and later by building or expanding urban rail systems. Examples of this development path include Singapore, Hong Kong, Tokyo and Seoul. Other cities – Bangkok, Kuala Lumpur and Jakarta, for example – are taking a different trajectory, trying to cope with rapid motorisation mainly through road building (Barter, 2000).

## 2.2 Urban density and modal choice

The decisions taken in favour of one of these two major development paths do not only concern the competitive relationship between the urban transport modes, but also shape urban development beyond the transport sector. Where transport is more based on transit, a city grows differently than in a car-oriented development paradigm.

The specific character of an urban transport system – in the table ranked according to the

share of private vehicle use in commuting - is of course not only a consequence of transport policy and land use strategies but also strongly influenced by average income. In low income regions where car ownership rates are low, dependency on public transit is generally high. The per capita living space area is low – in China about 6 m<sup>2</sup> per person, compared to about 60 m<sup>2</sup> in the US and about 30 m<sup>2</sup> in Japan – and urban population density is high, enabling transport companies a viably high level of patronage along fixed routes.

---

*“Density [is] a good initial indicator of a transit-friendly urban form.”*

---

Transit-oriented urban development aims at supporting structures which encourage public transport and discourage car use. But land use planning can only resist the spread of car use to a limited extent. This has been exemplified by the European experiences, where a degree of car-based sprawl has taken place despite land use planning efforts. But the results are much better than in the US, and the Asian examples of Singapore and Hong Kong (and recent European examples such as Zurich) show that public transport can gain high acceptance in cities with relatively high income.

Figure 3 indicates that lower urban density increases car dependency, with all the associated negative consequences for energy consumption and greenhouse gas emissions from the transport sector.

The graph relies upon the same database as Table 3. The general findings and main conclusions are supported by the results of a worldwide survey conducted by the International Association of Public Transport (UITP) (Rat, 2001), although the exact figures differ somewhat. Table 4 relates urban density to the aggregated shares of walking, cycling and public transport, and gives data on travel cost as a percentage of GDP, annual per-capita travel distances and related energy consumption.

The parameter “population density” stressed by Newman & Kenworthy and UITP is certainly not the only element of a transit-oriented urban transport system. Gorham (1998) explains:

Recent research on the subject, however, has de-emphasised the role of density per se, because, first, as a concept and measuring tool, it is often vague and improperly used, second, it may not be a particularly accurate measuring tool for describing those features of land use which most influence travel behaviour, and third, there may be other land use policy tools which are more effective in inducing sustainable travel behaviour than simply density.

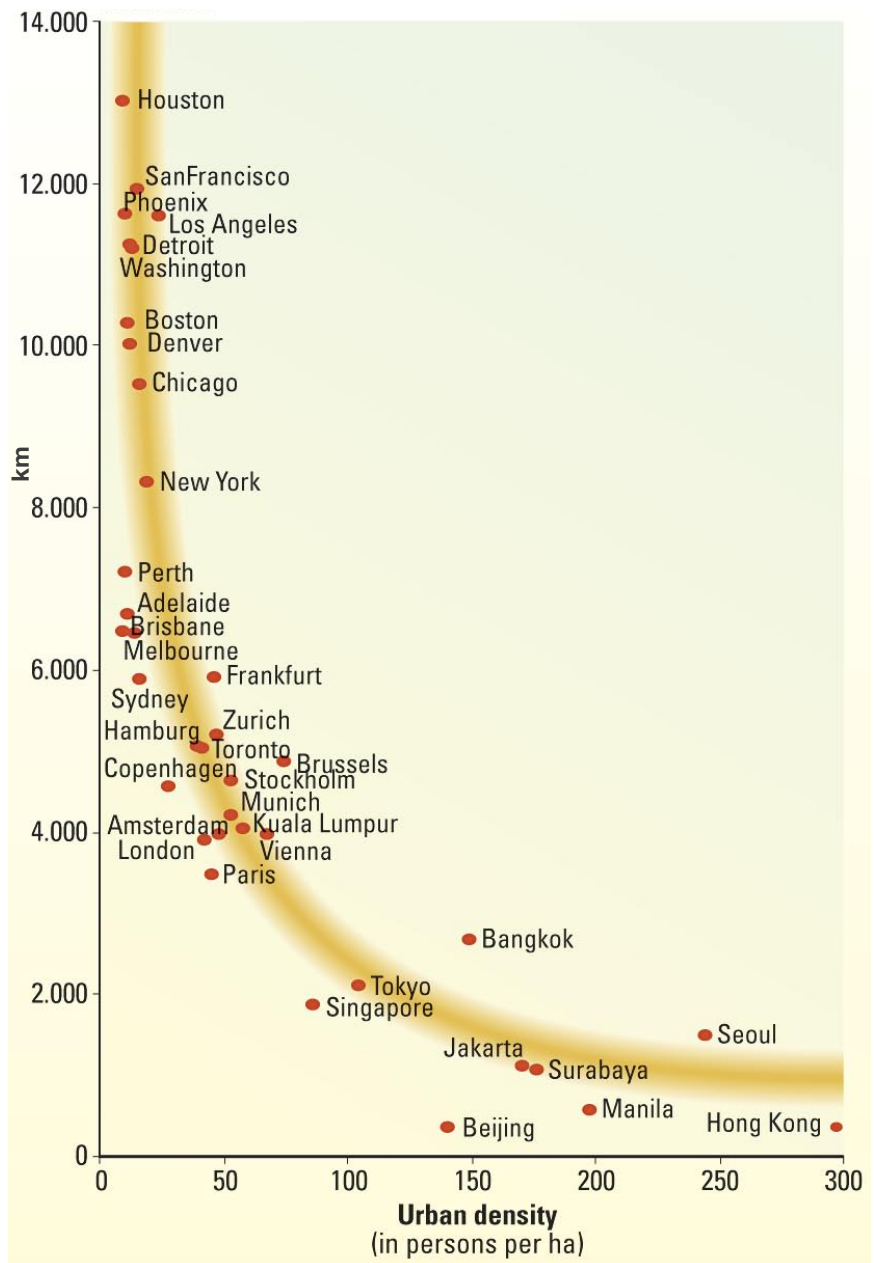
Other aspects of urban forms – that is, other than density – include land use mix, orientation of buildings towards the street, street pattern and layout, street widths, and various other urban design micro-features. A more detailed discussion of these parameters follows in Section 3 below.

Notwithstanding the importance of these other factors, however, density does seem to be a good initial indicator of a transit-friendly urban form, and a plausible basis for general reasoning about modal share and trip distances. High density urban structures automatically limit the space for cars, and mobility needs can better be served by public transport, walking or cycling. Photo 5 demonstrates space requirements of about 80 travelers either going by car, by bus or walking and cycling. The more environment-friendly modes make better use of road space.

**Table 3: Modal split in trips to work in Asian cities, early 1990s**

Based on O'Meara Sheeden, 2001, Kenworthy & Laube and others (1999), population and density from <http://www.demographia.com>

City	Population (million)	Population density / km <sup>2</sup>	Private Vehicle (%)	Public Transit (%)	Foot/Bike/other (%)
Bangkok	6.4	14,955	60.0	30.0	10.0
Kuala Lumpur	3.0	5,693	57.6	25.5	16.9
Jakarta	8.2	17,056	41.4	36.3	22.3
Tokyo	31.8	7,099	29.4	48.9	21.7
Manila	9.3	19,783	28.0	54.2	17.8
Singapore	2.7	8,697	21.8	56.0	22.2
Hong Kong	5.5	28,405	9.1	74.0	16.9



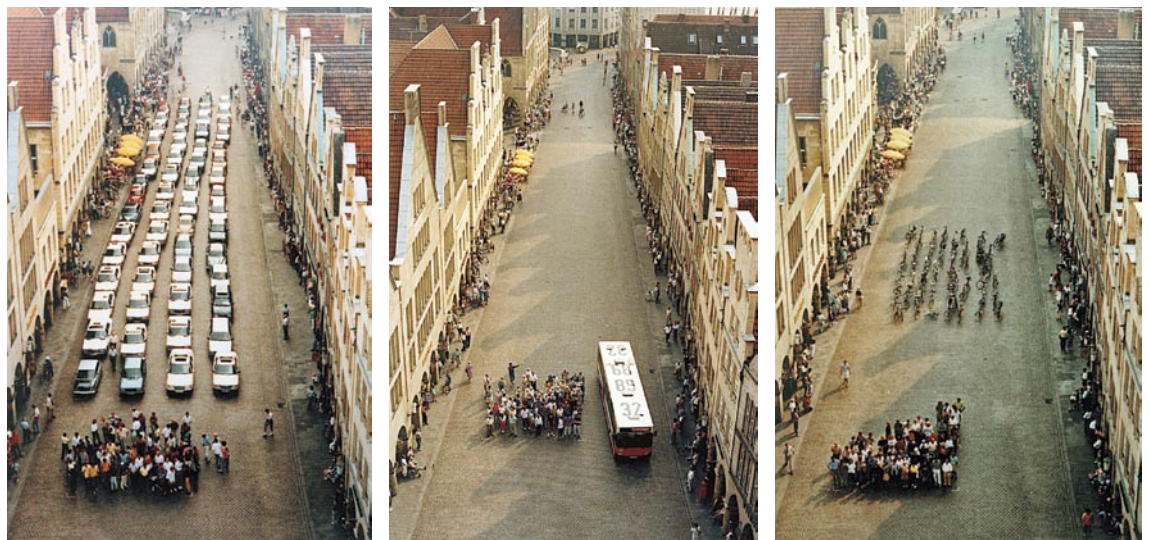
**Fig. 3**  
Annual car use per capita (1990) and urban population density.  
Kenworthy & Laube, et. al, 1999



**Table 4: Urban density and related transport parameters**

Rat (UITP), 2001

City	Population Density per ha	% walking + cycling + transit	Journey cost (% of GDP)	Annual travel (km/cap)	Energy (Mj/cap)
Houston	9	5	14.1	25,600	86,000
Melbourne	14	26	-	13,100	-
Sydney	19	25	11	-	30,000
Paris	48	56	6.7	7,250	15,500
Munich	56	60	5.8	8,850	17,500
London	59	51	7.1	-	14,500
Tokyo	88	68	5	9,900	11,500
Singapore	94	48	-	7,850	-
Hong Kong	320	82	5	5,000	6,500



**Photo 5**

*Space requirements of various modes.*

Poster from the State of North Rhine-Westphalia, seen in Muenster, Germany

### 3. Impact of land use on urban transport at different scales

Specific aspects of the transport and land use context described above by city-to-city comparisons show up at all geographical scales, in specific manifestations. The influence of different land use parameters on transport is discussed below.

#### 3.1 Property, building and site level; street characteristics

Trip frequency, trip distances and modal choice related to home, site and street characteristics have recently been analysed in the Netherlands (Meurs/Haaijer, 2001). The type of home (flat, detached/semi-detached, terraced house, with or without garden) influences personal mobility choice, as well as street characteristics (e.g. cycle route at front door, easy or restricted parking,

traffic calming). However, stronger effects were attributed to variations in neighbourhood characteristics.

The traditional urban housing type of “block wing tip edge building” (perimeter development) forms dense blocks along urban streets; this is still the typical configuration in and around many central districts of European cities. (Figure 4 gives an example from Berlin.) In many Asian cities this type of building prevails in quarters built up to the 1930s. Later on, line land development became the ruling paradigm of urban planners worldwide – with the consequence of increasing trip lengths.

The traditional road-side blocks of up to 6 floors have a number of advantages for sustainable mobility: Immediate access from house entrance to the pedestrian walkways, and close visual as well as acoustic contact between inhabitants and the pedestrian areas which make



**Fig. 4**  
*Block wing edge buildings (Berlin)*  
*(architectural model).*  
 City of Berlin

walking comfortable and safe. Building fronts typically are narrow, often with the combination of shops at ground level with flats on the upper floors. This type of mixed-use housing allows high accessibility to a large variety of urban functions within short walking distances. Access to bus and tram stops is easy, too. It has been found that the longer walking distances to bus and tram stops along rows of houses are accepted where building fronts are varied. Different styles and ground floor uses are to be preferred from that point of view, rather than large front lengths and monotonous faces of buildings.

With increasing motor vehicle traffic on the roads, however, living conditions are affected by noise and emissions. Reacting to these worsening environmental conditions, designs of buildings were changed in a way that the living rooms no longer faced the streets but were turned backward. Visual contact and public safety are suffering from this development, which makes walking less comfortable and safe.

In the second half of the 20<sup>th</sup> century, line land development became popular amongst architects and developers, locating buildings no longer front-by-front to the roads but at some distance from streets, surrounded by greens

and bushes. (See high-rise buildings in the upper part of Figure 4.) These buildings are not favourable locations for shops and services because of the distance to the street and to passers-by, resulting in increasing separation of functions. Although this site structure may improve environmental conditions, this type of development is less attractive to pedestrians, increasing average trip distances and reducing accessibility. The paradigm shift with respect to buildings has changed mobility preferences. Where the distances are growing and roads are wider, and parking lots are provided around the isolated buildings, car use becomes more comfortable than walking and public transport.

### 3.2 Blocks, residential areas, city neighbourhoods

Land use parameters at the neighbourhood level include density (in terms of addresses per hectare) and multiple configuration of functions, with easy access to all daily destinations by foot; locations for shopping, services, leisure locations, parks, etc. Most activities are made within the residential area as very short trips. This should focus attention of transport planners on the local level. Good pedestrian and bicycle facilities, connections through blocks



for non-motorised traffic, parking schemes and short distance access transit (below 300 metres) are important variables for encouraging choice of sustainable transport modes. Distance to public transport stops strongly influences mode choice (Wegener/Fürst, 1999).

The traffic load on local streets determines the quality of living in the residential area. Traffic calming increases the share of walking and cycling. High density of homes, achieved either by small dwellings or by multi-storey buildings, generates sufficient concentrated transport demand to support good public transit supply.

Space requirements for different transport modes vary significantly, as already illustrated by Photo 5. This is important for considering the kind of mode to be supported by urban transport planning. In order to provide mobility opportunities for a certain amount of persons travelling, buses, pedestrians and cyclists make better use of scarce urban space than automobiles. Approximate maximum passenger flows per lane is given in Table 5.

Car ownership inevitably requires urban land consumption even when the car is not moving, thus reducing the opportunities for other land uses. Roadside parking occupies scarce land resources needed for improved public space, bus

lanes, bicycle lanes, and improved traffic flow. One passenger car requires about 10 to 15 m<sup>2</sup> at the roadside. For parking lots one has to calculate twice as much use of land space to account for access and egress (Gorham, 1998). For a rough estimate of the accumulated land coverage, every car can be estimated to be associated with 1.5 parking places at various locations (home, office, shopping, etc.), and two-thirds of these places can be assumed to be off-street. This leads to more than 3 km<sup>2</sup> parking area requirements for an urban fleet of 100,000 cars.

Private passenger cars should park in commercially operated parking lots or garages, or on private property. Vendors should leave space for pedestrians, and bus stops also require space.

Driving behaviour and speed is directly related to road design. The faster a driver is going, the higher the risk of an accident, and the more severe the consequences. In traffic situations with cars, cyclists and pedestrians sharing roads, the highest risk is on the side of the “soft targets”. Figure 5 demonstrates the relation between pedestrian mortality when hit by a car and vehicle speed. Limitation of maximum traffic speeds to 30 km/hr has been identified as a suitable and cost-effective measure to reduce accident and fatality rates.

Road width in residential areas should not exceed 3.5 m, to prevent drivers from going too fast. Figure 5 shows the risk of fatal injuries to pedestrians in car accidents. Road width reduction may enable provision of additional space for pedestrians and/or bicyclists.

Average travel speed on urban roads in housing areas is in any case mostly below 30 km/h. On busy roads and in densely built areas, reduction of peak speeds via a speed limit of 30 km/h will not affect average car travel times significantly.

There is a well-known relationship between the width of a road and driving speed. While in most countries the maximum allowed urban speed is 50 km/hr, wide lanes and lack of police enforcement lead to much higher peak speeds, thus increasing accident risk and especially endangering crossing pedestrians. The extremely broad road arteries for instance in Chinese cities (Photo 6) tempt car drivers into higher speeds of 80 km/hr or even more between intersections,

**Table 5: Space requirements for various transport modes, under various operating conditions.**<sup>#</sup>

McNulty, 2002

Mode	Capacity scenario (users/hour/lane*)	Speed (km/h)	Space demand (m <sup>2</sup> per user)
Pedestrian	23,500	4.7	0.7
Pedal cycle +	5,400	12	8
Motorcycle ++	2,400	12	17.5
Car (urban street)	1,050	12	40
Car (expressway)	3,000	40	47
Bus (55 seats)	7,700	10	4.5
Bus or Tram (150 seats)	18,000	10	2
Tram (250 seats)	24,000	10	1.5
Metro rail	40,000	25	2.5

<sup>#</sup> These figures are not maximum values or typical speeds for all situations, but rather present the space required, under various conditions

\* The width of a lane is assumed as 3.4 m

+ One user per pedal cycle

++ 1.1 users per motorcycle

All public transport modes are assumed to be 80 % full.

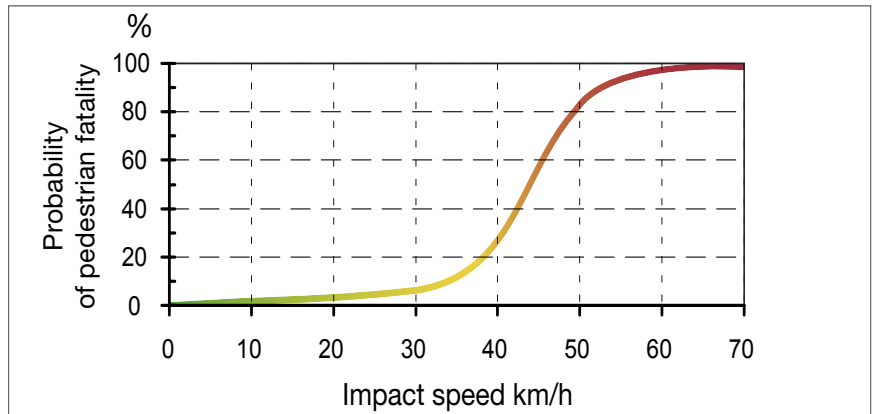


increasing not only risk and impact of accidents but also exhaust and noise emissions. Because road capacity restraints typically are caused by throughput at junctions, rather than by road dimension of the sections in between, road width could be reduced without negative impact in terms of congestion and travel time. This could either lead to improvements for pedestrians and cyclists, or provide options for greening along streets (Photo 7).

Ecological quality of urban greens along roads may not be high with respect to biodiversity of flora and fauna, but there is a positive effect in terms of walking comfort and microclimate, as well as for clearing run-off waters. These advantages have to be balanced with the road area requirements.

### 3.3 Municipal level: urban development and transport

Most cities in developing countries, but also in North America, show a functional classification of land uses varying according to the distance from the city centre (central business district or CBD). In the centre where land prices are highest we find high-rise buildings mainly for offices and some shopping facilities. (Some cities still have a traditional CBD core within the modern CBD). Housing density is low because of high prices. The inner city areas surrounding the CBD show a mixture of housing and commercial activities, typically in block buildings of 4 to 6 floors. In the outer urban areas, older housing



**Fig. 5**  
*Probability of pedestrian fatality by impact speed.*  
Barter et al., 2000

areas with detached and semi-detached houses mix with concentrations around sub-centres. Additional housing development concentrates near the outer boundaries of the city.

Figure 6 shows a model of this kind of urban structure, and indicates that the highest concentration of air pollutants from motor vehicles occurs on the radial arteries linking suburban settlement areas with the city centre. This is especially the case for carbon monoxide, hydrocarbons, oxides of nitrogen, and diesel particulates.

Basically, this radial type of urban structure provides relatively good conditions for public transport, as long as the main working sites and shopping facilities are in or near the centre. The main radial arteries and the circle roads can be served by highly efficient rapid transit lines. Berlin is a good example of this, with an urban rapid-rail system already established a century ago. This network has supported a rail-oriented,

**Photo 7**  
*Urban road space with green belt (Frankfurt). The green strip is the Zeil, one of Europe's premiere shopping streets.*

Karl Fjellstrom



**Photo 6**  
*A typical urban road in Shanghai.*  
Karl Fjellstrom





## 4. Urban growth patterns

Different models of urban growth result in various transportation systems and mobility patterns. The consequences of urban growth patterns are explained in the following sections.

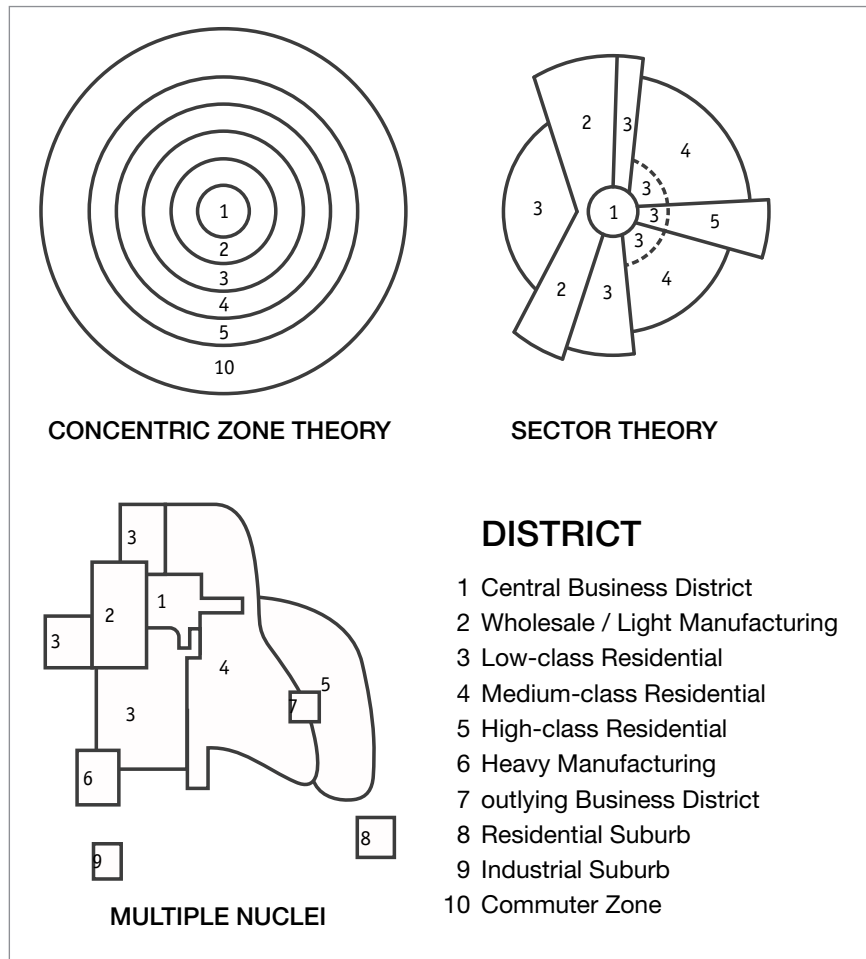
### 4.1 Simplified schemes

It is useful to analyse the urban structure and the distribution of activities in space, in order to understand current and future transport demand patterns. The following examples (see Figure 7) provide some insights into urban dynamics.

*“The radially oriented city ... allows supply of high-volume rail and bus systems.”*

The model of concentric zone development is rather simplified; in reality we find ring segments with specific land uses, as well as segmentation of the population according to socio-economic parameters: High-income groups settled in the up-wind side of the city while low income people in the down-wind side suffered from industrial activities. In some cities, some types of locations have concentrated in certain sectors. This has been especially marked in early-industrialised city regions. Another structural element has arisen from the fact that the growth of cities led to the inclusion of formerly independent cities, which became sub-centres.

The differences in urban development structures have consequences for the demand and supply of transport services. The radially oriented city will show articulated arteries leading to the heart of the city, allowing supply of high-volume rail and bus systems. The sectoral development type will not have a clearly structured demand, and will not support high-volume public transport but provides chances for short distances between housing and other functions; non-motorised modes may reach high shares. The multiple-nuclei type provides even more problematic conditions for efficient public transport supply, and distances often may be too long for non-motorised trips. Here, the private passenger car will attain high market shares, especially as average incomes increase.



### 4.2 Transport consequences of urban growth

As has been seen, it is important to keep the spatial conditions in mind when discussing transport options. The current distribution of land uses and activities within the urban boundaries is a result of historical developments. The transport system now has to serve a broad range of urban structures, which partly evolved in times of former transport modes, and offers unfavourable conditions to current traffic. In general terms: Urban design and modern transport often do not fit together.

Until the 19<sup>th</sup> century, the diameter of cities did not exceed a distance that could be traversed by foot; the street patterns and road dimensions were designed according to the needs of horse-cars. The growth of the cities during the industrialisation process brought an urgent need for fast mass transport; streetcars and buses served the arteries, leading to a kind of decentralised centralisation. People could reach their homes

**Fig. 7**  
*Urban development schemes.*  
The University of North Carolina at Charlotte, 2002. <http://www.uncc.edu/~hscampbe/landuse/b-models/B-3mods.html>



by walking from public transport stops. Main development took place within walking and cycling distance from these stops.

Broad availability of private cars since the 1950s and 1960s began to support sprawl of low-density settlements. In highly motorised regions, this development is still continuing. In developing countries, the process is on the rise. Due to this revolution in transport technology, but also as a consequence of social changes within societies, the urban zones around CBDs became less attractive, and public security vanished. Especially in the US, social stability eroded in parts of the city, and those who could afford to move settled in the suburbs. Although in recent years remarkable efforts have been made to revitalise American cities, the distribution of wealthy citizens is still according to a donut-type of pattern: the middle and upper classes are concentrated in a suburb-ring around the traditional city, with the city centre losing economic momentum.

Overlay of concentric-model development and local particularities has led to numerous variations in urban development, as shown in the schemes in Figure 7. Social segregation in housing and flourishing light manufacturing within cities may lead to situations where some employees still live quite near to their work places, but with more rapid social and economic developments taking place in the outer areas. It has to be kept in mind, too, that more and more non-working trips become important, as shopping malls and other services move outward. This is especially the case in middle-income Asian and Latin America regions, following trends in Europe and the US. The core cities lost population, and the surrounding areas change from agricultural to housing areas. Most large cities transcend traditional municipal boundaries and are now extended urban (metropolitan) areas spanning hundreds of square kilometres, and integrating previously independent villages and towns.

## 5. Growth beyond city borders

Due to population growth, but also caused by changed preferences of settlers and commercial investors, urban functions are spreading beyond traditional city borders. The process of suburbanisation shows various faces in different parts of the world and under different political, social and economic circumstances. For middle and high income groups, the basic reason for private households moving outward, away from the dense urban areas to more rural structured places, are lower market prices for single-family homes and better environmental qualities. In low income countries with high population growth, semi-legal settlements and more recently large housing estate developments (see Figure 20) drive the outward growth. Suburbanisation and rural settling of private housing often leaves daily activity patterns still oriented towards the cities, and initiates transport flows over longer distances. While high-income commuters and shoppers increasingly use the private car, travel conditions for people with low income depending on public transport are difficult and deteriorating in most developing cities.

Early experiences with growth of urbanised areas in industrialised countries may be useful to discuss options for steering the development in developing countries. Following economic and social development, and rising average incomes, similar trends are emerging in developing countries, and can be expected to strengthen. In Europe, the relatively densely built-up city still dominates in terms of population density and centrality of functions, but suburbanisation has changed the distribution of functions. The interaction between urban development and transport infrastructural development, as described in Figure 1 (“traffic spiral”) has enabled people to live outside, and work and shop within the traditional city boundaries. Also, the city is still the cultural and social centre. The resulting travel demand is based to a large degree on the private car, but many European cities have kept a type of semi-centralised settlement that enables travelers to use regional rail lines, linking sub-centres with central urban areas. In the US, cities have lost their structures, following the various waves of decentralisation

enabled by ownership of private cars, lack of land use regulations, low gasoline prices, and consumer preferences for large housing lots.

How are the trends of urban area growth and suburbanisation materialising in developing countries? There are many different patterns of growth to be observed worldwide. Urban boundaries are spreading outward; a phenomenon even visible from space. Satellite imaging provides pictures of various regions (see for instance <http://www.geog.uu.nl/fg/UrbanGrowth>, featuring the West African case of Ouagadougou (Burkina Faso), and other examples). Due to only recent availability of this kind of technology, only trends since about the mid 1980s can be traced. The pattern that mostly occurs is development along existing radial arteries and newly built ring roads (see also Section 7), followed by fill-in of the remaining segments.

There are not many maps available from cities in developing countries describing urban growth and change in land use over long time. Figure 8 illustrates the development of urbanised settlements of the City of Dar Es Salaam during 1945 to 1998. Figure 9 shows the development of urban growth of the City of Cairo but covers only a short time period of 1968 to 2000. In both examples we find the typical pattern of growth along traditional radial arteries in early years, and a more disperse development between these main roads in later years, supported by increasing private passenger car use.

The easiest explanation for geographical growth is population growth caused by natural parameters and by migration – but this is only part of the reason, because in most cases urban areas grow by a faster rate than the population. Driving forces also include life-style parameters and economic requirements. These cannot be discussed here in detail, but the transport aspects of the urban growth form shall be investigated.

While development along main roads can efficiently be served by large buses, disperse settlements depend on mini-buses as well as on walking and cycling. Increasing travel times for commuters working within the traditional city areas – for example in the informal sector as vendors – impose serious burdens, especially on the poor. Disperse development will in the longer term create demand for automobile own-

ership and use, thus initiating a vicious cycle of traffic increase, congestion, road network extensions, and environmental degradation. Comparisons between the historic development of European and North American cities with cities in the developing regions of Asia, Latin America and Africa is useful with respect to actual policy-making in developing countries.

---

*“Disperse development will in the longer term create demand for automobile ownership and use, thus initiating a vicious cycle of traffic increase, congestion, road network extensions, and environmental degradation.”*

---

The rapid growth of cities and the rapid motorisation in developing countries confront planners and policy-makers with similar challenges as already occurred in highly motorised societies. But while the basic process of extending urban area and transcending traditional municipal boundaries may be the same in industrialised and in developing countries, the speed and the spatial structures differ. Sprawl development has not yet become entrenched in developing countries, because population pressure and economic conditions still result in dense growth ring and high density satellite cities, still allowing transport services to be provided efficiently.

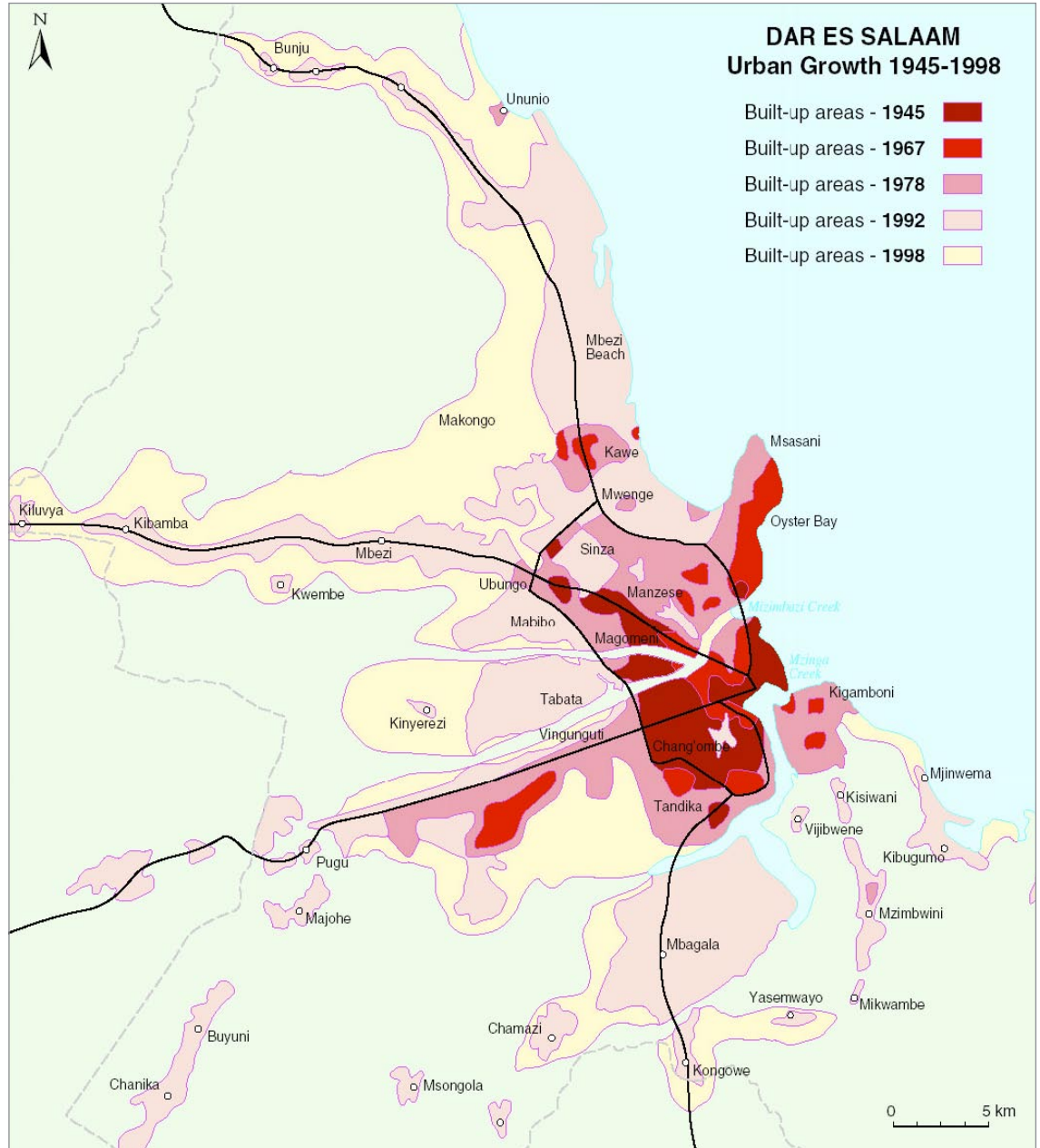
It will be important for the public budgets to maintain dense structures in the growth dynamics, and to avoid sprawl in future development. Also aside from the transport and environmental problems, costs of low-density, disperse development in general would impose severe burdens on developing cities. This includes costs of infrastructure like water supply, wastewater treatment, and electricity supply, and also health care, education facilities, and so on.

Administrative structures often have not developed in line with the geographical expansion of urban areas. There are different ways to cope with the situation: One strategy is that municipalities extend their administrative borders integrating those urbanised and suburbanised areas which functionally belong together. There

**Problems of sprawl**

The main problems of sprawl-development are:

- High average trip distances for commuters,
- high dependency on private passenger cars,
- noise pollution, traffic accidents
- high level of transport-related air pollution
- congestion on main arteries,
- high transport energy consumption,
- poor market shares of transit due to economically unfavourable settlement structures,
- dangerous conditions for bicyclists and pedestrians,
- long trip lengths for pedestrians due to multiple barriers.



**Fig. 8**  
*Urban growth beyond traditional municipality borders (Dar Es Salaam).*

Research data supplied by John Briggs, University of Glasgow and Davis Mwamfupe, University of Dar es Salaam. Cartography by Mike Shand, University of Glasgow

is the example of the City of Shanghai that in its first Master Plan in 1953 extended the urban area from 140 km<sup>2</sup> to 600 km<sup>2</sup>, and since then has subsequently extended the municipality area to 6,340 km<sup>2</sup>. (Chinese municipalities in general also include rural areas.)

Another formal strategy is the establishment of regional administrative entities above the municipality level to ensure coordinated policy

and planning. The balance of responsibilities between such bodies and the traditional municipalities is crucial for efficient management of problems.

Options for shaping urban growth in a sustainable manner – both within cities and beyond traditional municipality borders - will be discussed in Section 9.





**Fig. 9**  
*Urban growth beyond traditional municipality borders (Cairo).*

Metge, 2000, <http://wbin0018.worldbank.org/transport/utstr.nsf>

**Trip generation based on a gravity model**

According to a gravity model such as Figure 10 below, the transport volume increases when:

- the benefit of change of place, in the sense of reaching a new place but also of leaving the present location, increases,
- the total resistance against overcoming distances (costs, time, inconvenience, damage) decreases.

**6. Trip generation & mode choice related to land use parameters**

**6.1 Basic principles**

Areal extent, density and variety of locations, and level of activities determine trip generation within an area. Transport mode choice depends on the attractiveness of the area’s infrastructure regarding car use, public transport and non-motorised traffic. In mathematical models calculating the transport demand resulting from trip generation, the geographical distances between locations are expressed in terms of resistance functions, comprising mainly of price and travel time. The larger the number of persons living, working and shopping at one location, the more concentrated is the flow of travelers between these locations. Small and geographically scattered locations, on the other hand, lead to small and scattered demand flows. The formula (Figure 10) given below is based upon the experience that trip numbers are linearly related to size of the location and inversely related with second order travel resistance (gravity model).

Shorter distances between locations increase travel demand between those locations, given constant travel speed. But it also should be kept in mind that travel speed improvements generate more trips between locations (origins and destinations). Increase of travel speed in one mode changes travellers’ preferences towards this mode. In other words: More roads for cars increase car traffic volumes, because they create competitive advantages for road traffic. Since in most developing countries social cost of car traffic are externalised, travelers’ decision to choose a car instead of public transport can be interpreted as misallocation of resources.

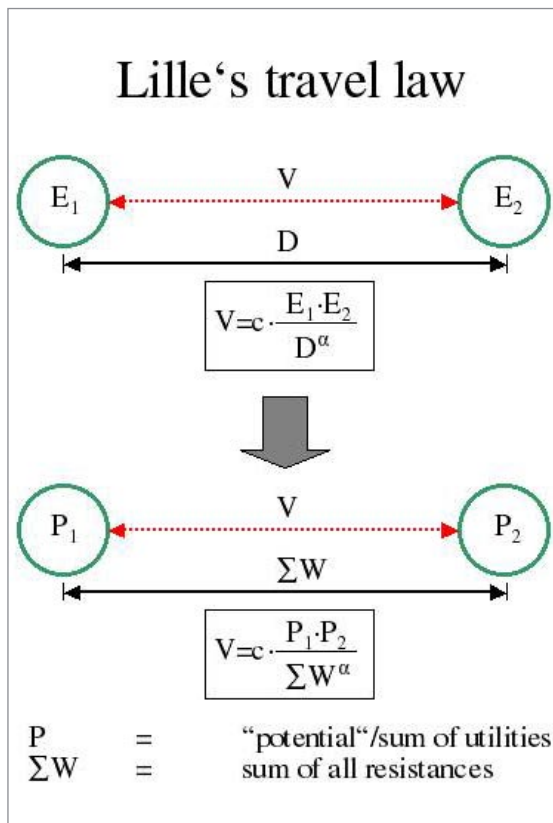
The aggregated demand in car traffic not only causes problems like congestion and air pollution, but creates a feedback into the spatial structures.

Changes in the transport system cause changes in spatial structure in several respects: Firstly, space requirement for one mode reduces available space for others and imposes barriers to their use. More and broader roads reduce accessibility of destinations by foot and bicycle. On the other hand, bus lanes reduce space for other motor vehicles, thus discouraging car use. Secondly, better conditions for faster modes initiate spatial re-orientation of citizens and commercial stakeholders, leading to increased trip distances. Other shopping facilities can be reached within the time available, and on the other hand developers will choose locations for their investments according to the changed accessibility structure. Transit-oriented urban development will lead to characteristic forms of urban growth, car-oriented development to others. These effects will be dealt with later.

**6.2 Land use and travel demand in urban areas**

In real-world cities, functional relationship between locations will be very specific, because these carry out different urban functions. Evaluation of these functions is a first step to identifying travel needs and to optimising both the choice of locations and the travel needs. Figure 11 illustrates functional relations between various urban locations, leading to travel demand.

Trip generation patterns and modal choice in cities within developing regions differ



**Fig. 10**  
*Trip generation based on a gravity model.*  
 Braendli, 2001

significantly from North American or European conditions because of differences in income, trip purposes, vehicle ownership and also quality of service within the various modes. Social segregation shows up in data on income gaps between various parts of the cities, and location influences perception of problems. While the main complaints of citizens in high-income areas may focus on congestion, concerns of people living in poorer areas will focus on affordability of bus tickets, not to mention sheer absence of transport infrastructure and services in informal settlements at the fringe of the cities. Squatter housing, for example, is estimated to house up to 60 percent of the urban population in Caracas and Dar Es Salaam, and 50 percent in Karachi ([http://www.wri.org/wri/wr-96-97/up\\_f3.gif](http://www.wri.org/wri/wr-96-97/up_f3.gif)).

Household surveys in major cities of developing countries have resulted in masses of data on travel behaviour related to income, settlement structure, trip frequency, modal choice, and trip distances. Because land use structures and social status typically correspond in cities in developing countries, mobility data reflects both sets of parameters. This complicates the identification of variables to be used as a basis for formulation of planning objectives and policy measures. Because of the broad range of problems, transport planners tend to separate and to simplify problems, treating parts of the systems separately. It has become common to separate road traffic problems from public transport aspects, for instance. Survey results on car trips are fed into traffic flow models; these support identification of bottlenecks, finally leading to road construction projects. Non-car trips, on the other hand, are allocated to the public transport network alone. Often there is no integrated modeling, and modal shifts are not in the focus of planners. Further deficiencies occur with respect to short non-motorised trips, which are under-estimated, and typically neither show up in problem analysis nor in the formulation of strategies.

These deficiencies in analysis of mobility structures are of special importance for low income households in densely populated areas, both within the traditional urban boundaries as well as in the informal settlement areas. This bias



Fig. 11

*Functional relationship between locations.*

Wuppertal Institute

in perception results in a bias in policy and planning priorities: The car is regarded as more important than is justified in relation to the real needs of the majority of the people, and non-motorised mobility is neglected. In public transport, there is a bias towards longer trips on major arteries, under-estimating the importance of trips within neighbourhoods, and mini-buses.

---

*“The general rules of land use planning for sustainable transport – reduce the need to travel and the trip distances, support walking, cycling, public transport, restrict car use – have to be adapted to local circumstances.”*

---

Social and spatial differences, and the separate modeling practices make it difficult to draw general conclusions for urban transport planning. It is even more difficult when it comes to the land use and transport interaction, because of the close relation between social status, land use structure and mobility. The general rules of land use planning for sustainable transport – reduce the need to travel and the trip distances, support walking, cycling, public transport, restrict car use – have to be adapted to local circumstances. This includes consideration of the political feasibility of different measures.

It will not be possible to locate all functions within large cities in close proximity to each other, thus minimising travel kilometres. But



the locations should be structured in a way that major shares of trip demand are aimed at public transport, which in turn requires high land use densities and – wherever possible – mixed land use. There are two main reasons:

1. High quality public transport services consisting of a dense network of routes and short waiting times at the stops can only be operated economically efficiently when the ratio of customer trip kilometres to bus kilometres is high: in other words high occupancy rates of the buses are guaranteed.
2. Mixed use of urban areas, bringing together housing, working, shopping and leisure will enable part of the people to reduce trip distances, but the main benefit for public transport lies in the multi-directional distribution of demand: This allows high occupancy rates in different directions over the day. If the opposite planning strategy were to be followed, for instance housing in one sector of the city, working in another and shopping and leisure also concentrated apart from housing areas, average occupancy of public transport vehicles would vary extremely according to time and direction, leading to inefficient and uncomfortable load factors and fleet utilisation.

## 7. Influence of transport on spatial development

While the influence of spatial structures on transport demand is dealt with in traditional transport master plans, the rebound effects of transport onto spatial development have not yet been a focus of planning. The traditional computer model for transport master plans starts with the evaluation of origins and destinations in space, and calculates trip generation (see Section 6 above). But how is the choice of locations for housing, businesses and other purposes influenced by transport parameters? Investors will consider accessibility of customers in choosing locations for shops. Housing areas will be preferred by families looking for a house, which provide easy access to work, shopping, leisure and other activities of interest; provided a high quality living environment is available in such locations.

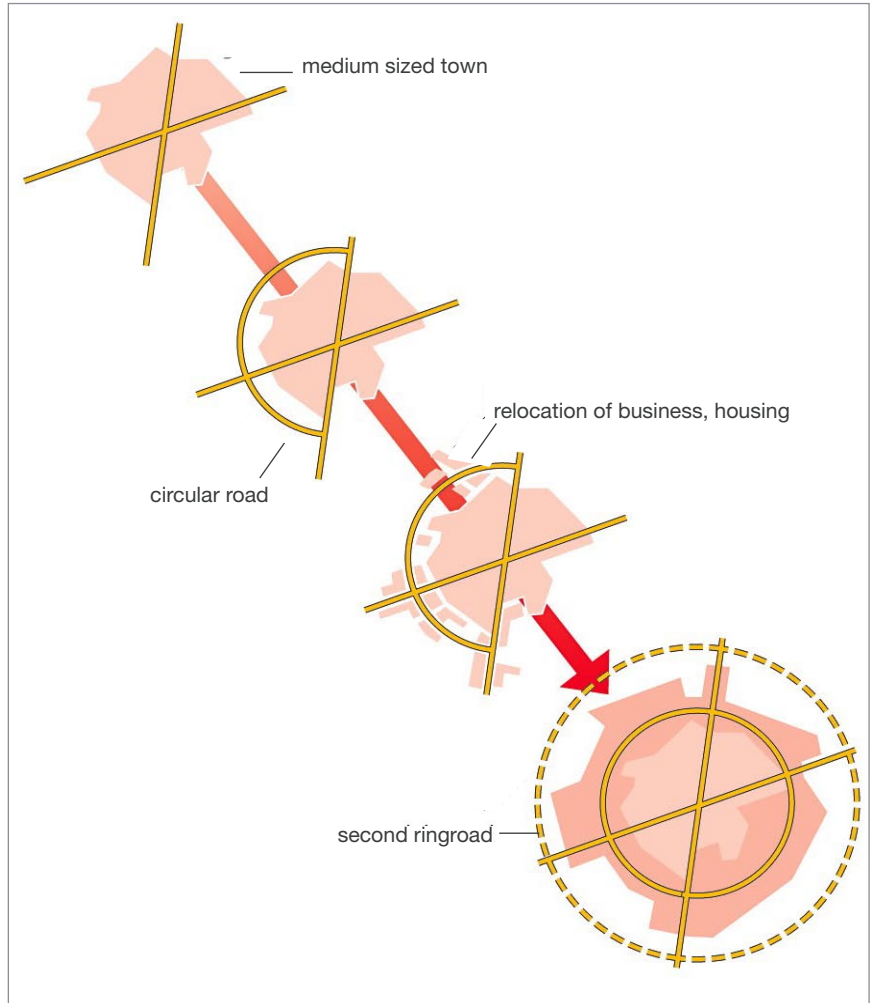
Development of transport infrastructure and of transport services changes accessibility patterns and influences locational decisions of private households and of businesses. These decisions shape the structure of the city and of the surrounding areas, and generate new traffic demand patterns. These spatial changes normally are not taken into consideration in the course of traditional transport planning. When additional road space is expected to alleviate congestion in a certain corridor, the shifts in locational preferences of private and commercial investors may lead to additional trips and to larger trip distances, and may even cause more traffic within that respective corridor.

The traffic-inducing effect of infrastructure extensions can be interpreted as a positive feedback system. The intermediate steps are exemplified in Figure 12, showing a simple example of a small settlement at a road junction where a circular road has been added. In this example, the circular road provides a new nuclei of development, modifying investment priorities and initiating new trip relations. While the starting point for constructing the circular road often are complaints about through-traffic the traffic load resulting from the road network extension more and more results from trips between the centre and the new suburban locations. As a

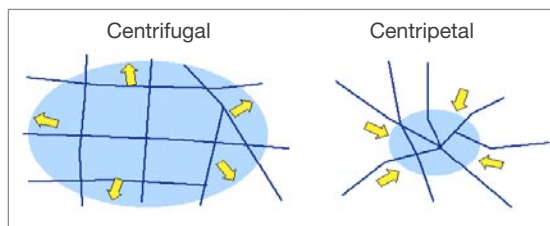
consequence of increased trip distances and urban traffic volumes following the geographical growth of the city, further road construction programs will be demanded.

Some analyses in the US have led to the argument that circular roads may attract investors that otherwise would choose locations further out in the countryside. This has been supported by evidence from Houston (Bolan *et al.*, 1997). Even if local conditions there – with a road network so dense and no land use ordinances – are comparable neither to Europe nor to developing countries – there may be some positive effects of highways bundling development (see also the case of the “edge city”, Section 9.3). The US type of centrifugal road network design supports sprawl (Figure 13), while circular road investment may even cause denser developments in some situations.

The interaction of transport infrastructure construction and urban development can be studied in numerous real-world cases in the already highly motorised countries. Where a new high-speed motorway leads from an agglomeration through rural areas (and further to a distant agglomeration), part of the private households and commercial enterprises move out of the agglomeration and settle along that motorway on cheaper and easily accessible land. Under the principle of travel time constraint (see Figure 2), the process of economic optimisation leads to more distant trip relations if travel times are shortened by high-speed transport infrastructure. Which settlement patterns develop now depends on transport services provided and the kind of infrastructure built. Within certain travel times (and cost) private motor vehicles and trucks make other locations more easily and rapidly accessible than places along public transport routes. Dense road networks and high car ownership rates support sprawl development while rail networks support cluster development around train stations. Under low car ownership conditions, and a bus-based public transport system, development will preferably take place along the main arteries well served by buses (see Figure 14). At longer distances from the centre, development may concentrate like “pearls on a string”.

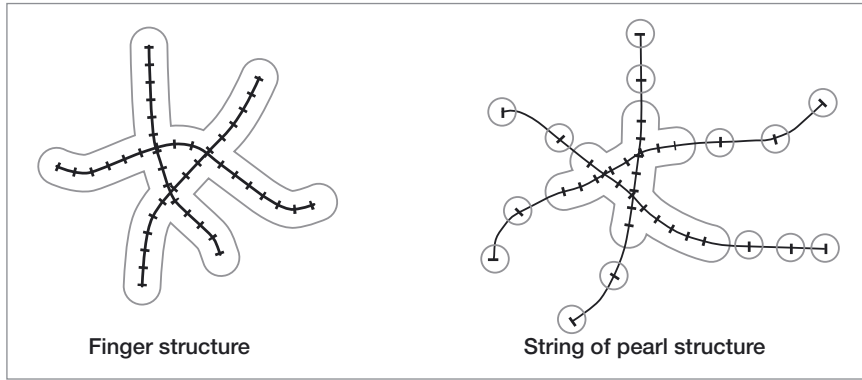


**Fig. 12**  
*Circular road and urban relocations.*  
Wuppertal Institute VE-265e/96



**Fig. 13**  
*Spatial effects of various road network designs.*  
Rodrigue, 2002

In any case, private households and commercial companies will take advantage of any better access (in terms of cost of transport, both out-of-pocket cost and other cost like comfort etc.) to certain areas following transport system improvements. System improvements consist of infrastructure extensions and new transport services offered, but are also caused by vehicle technology.



**Fig. 14**  
*Land development along transport infrastructure.*

Book & Eskilsson, 1996, quoted by Ranhagen & Trobeck, 1998

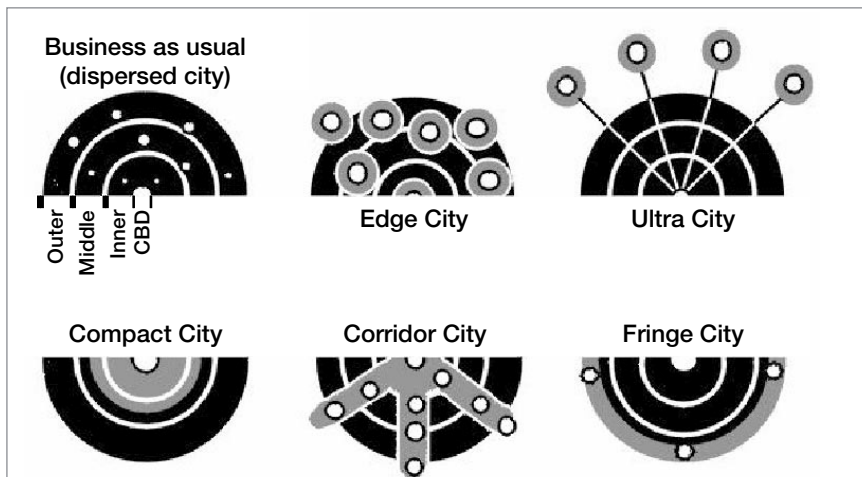
The link between transport and land use has not sufficiently been reflected in classical transport planning models, which aim at improving traffic conditions under existing spatial configurations, not taking into account the market-driven choices of locations. Observations and computer modeling have given some insights into these mechanisms. The land use patterns evolving from certain transport planning strategies show significant variables related to income, population increase, economic growth, sectoral dynamics, and also land use planning schemes. Migration control policies as e.g. in China, and land ownership regulation will lead to less disperse growth than in fully liberalised conditions.

From an environmental perspective, a corridor-oriented or pearl-chain development is preferable, based on regional transit systems, as has been demonstrated by computer model application in the case of Melbourne, Australia (Newton, 1999). Several basic prototypes of urban development forms were compared (see Figure 15):

- **Business-as-usual city** – simply an extension of current development practices.

**Fig. 15**  
*Structural options for urban growth.*

Newton, 1999



- **Compact city** – increased population in the inner suburbs.
- **Edge city** – growth in population, housing density and employment at selected nodes, and increased investment in freeways linking these nodes.
- **Corridor city** – growth along arteries arising from the central business district, radial links and upgraded public transport.
- **Fringe city** – growth predominantly on the outskirts.
- **Ultra city** – growth in regional centres within 100 kilometres of the CBD. High-speed trains link the regional centres to the city heart.

Under an assumed urban population growth, the corridor type of city development provided the most favourable results in terms of vehicle mileage, energy consumption and population exposure to air pollution.

These findings are in line with experiences from European cities that had established development corridors based on rail in early phases of urban growth at the end of the 19<sup>th</sup> century. Where this type of rail infrastructure had been established, the stations formed nuclei of dense development, initiating a “de-centralised centralisation”. Nowadays, with bus transport dominating and the private automobile being accessible to part of the population in developing countries, the corridors will become more like bands rather than pearl chains, but the basic positive effects, as shown by the Melbourne modeling, will show up. The advantages of the corridor or pearl chain type of structure both result from savings in travel demand and in higher public transport shares.

In order to influence spatial development in that direction, transport planning preferences and land use planning principles have to be coordinated. Disperse urban and regional development is both a result of investment priority for roads, and weak land use planning. The relatively strong planning ordinances in Europe and Japan have prevented towns and regions from developing in the same disperse way as in the US, where zoning ordinances were not effectively implemented. Only in recent years there have been some efforts in the US to



communicate planning schemes as legitimate measures for regulating property rights.

Spatial development cannot simply be directed by planning schemes and infrastructure investments, but is also a consequence of fiscally influenced prices of the various transportation modes. Section 9 discusses planning and transport investment concepts from Europe and Japan, which have been successful in achieving environmentally friendly urban growth structures. Both regions have high taxes on transport fuels and motor vehicles.

### Land use models

The process of coordinating computer models for land use planning and transport (often also including air pollution models) at various levels and scales is known as "nesting".

Various decision support systems and computer modelling applications exist to assist planners to predict the impact of transport strategies and make recommendations based on those predictions.

More complex land use models have been developed to model a larger range of factors and relationships that affect land development. These models may contain both a transportation and a land use modeling component, or they may consist of a land use model that interfaces with an existing regional travel demand model. They typically cover an entire metropolitan region and consist of a zonal structure, similar to travel demand models. Consistent with regional forecasts of population and employment, they allocate development to each zone based on transport accessibility, land prices, available land by development type, and/or other parameters. The models are typically calibrated using historical data on land development, prices, transport accessibility, and other factors.

Examples include DRAM/EMPAL (the most widely used US model); UrbanSim (<http://www.urbansim.org>); TRANUS (<http://www.modelistica.com/modelistica.html>); MEPLAN (<http://www.meap.co.uk/meap/ME&P.htm>); and Smart Places (<http://www.smartplaces.com>).

Adapted from US EPA, Modelling and Forecasting Methods, <http://www.epa.gov/otaq/transp/modlmeth.pdf>

## 8. How to organise land use

In the previous sections it has been shown that land use and transport planning should be coordinated, due to the various interactions and dependencies between these planning fields. In addition to the coordination of these two fields, the coordination of different planning levels must be achieved.

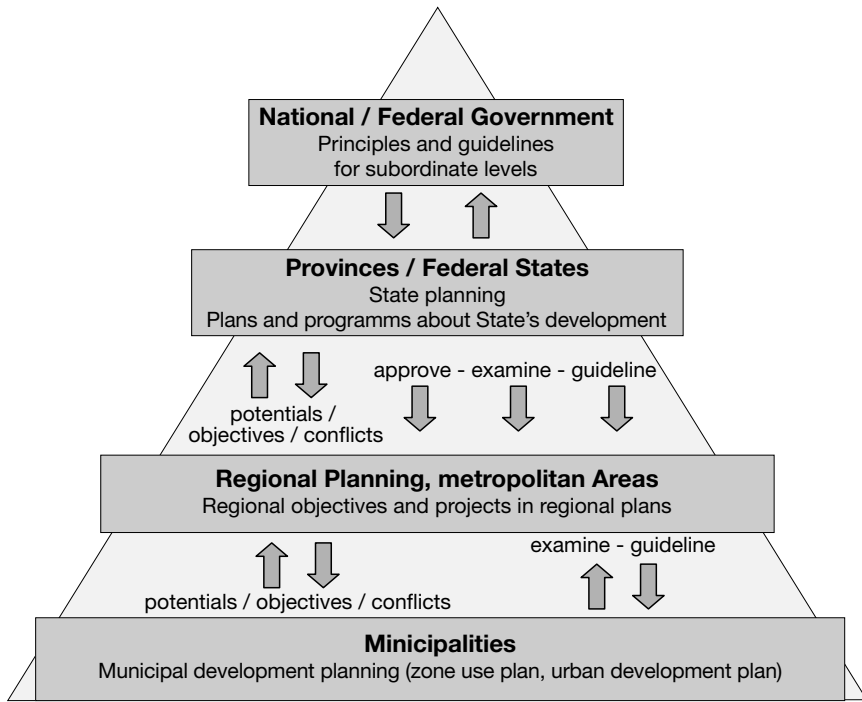
The following section deals with legal and organizational aspects of these different types of coordination. Examples are given, showing how to consider transportation aspects in land use plans.

### 8.1 Legal and organisational set-up

Sustainable land use is primarily a local issue but needs to be promoted and guided by national and provincial strategies and resources. The aim is to ensure that development takes place within a spatial framework.

Decisions about land use should be jointly taken at the regional, municipality and district levels. According to the principle of subsidiarity, details of planning ought to be decided on the lowest level possible because of the better familiarity with the problems. On the other hand, these decisions and plans have to fit into the guidelines and the framework of spatial planning issued at the provincial and national level. Figure 16 shows the vertically structured pyramid of levels of responsibility. From the organisational perspective, the pyramid also illustrates the transfer of information top-down and bottom-up, including the practical links between levels in the mapping procedures. Lower-level maps will be based upon the frame delivered from the upper levels, and vice versa.

As different administrative and political structures of responsibility can be found in the various developing countries, the scheme has to be adapted to local conditions. With respect to the links between land use and transport, close cooperation between the responsible bodies is necessary. Growth of cities beyond their traditional borders may have led to the establishment of metropolitan authorities between the municipal and the provincial level. Diverse legal provisions can be found for these bodies,



**Fig. 16**  
*Vertical integration of different planning levels.*

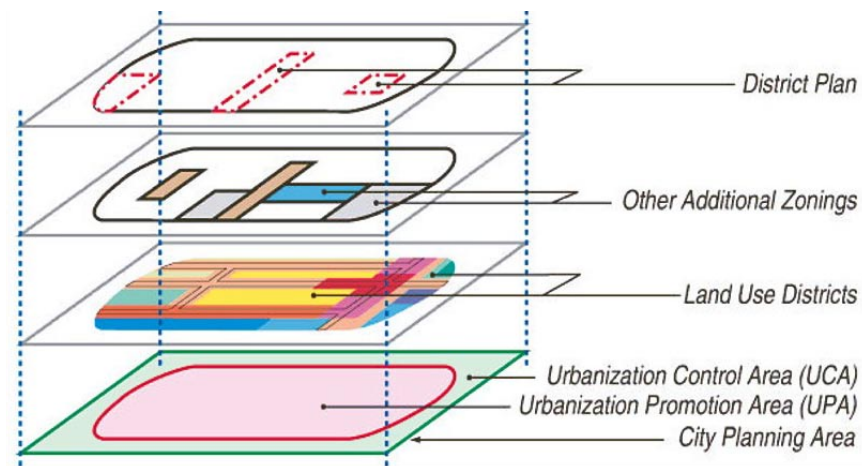
Wuppertal Institute

ranging from the status of informal commissions providing only a platform for exchange of views, up to complete administrative levels with a clearly defined mandate for decision-making.

Cooperation between the various hierarchical levels should be organised according to the principle of “counter-current”. Plans designed for instance in urban district level have to be agreed upon by the upper level (the municipality) before implementation; permission has to be granted from the upper to the lower level if the formal requirements are met. The same happens with land use planning on municipal level towards the regional planning authorities, and vice versa. When the municipal urban development plan fits into the regional development scheme,

**Fig. 17**  
*Concept of a land use planning system: Overlay of land uses.*

Mori, 2000



permission has to be granted by the regional body. Again, for regional planning and decision-making, guidance will be given by spatial planning from the provincial level, and so on. Planning at the state or provincial level will for instance be concretised as a “Provincial Development Plan”, regulating functions of the cities and rural land uses for agriculture, protected areas for national habitats, inter-urban transport infrastructures, and other sectoral issues. The plans may be drafted in a scale of 1 to 50,000 or even larger.

Regional planning may be concretised in a “Regional Development Plan” providing more details of land use drafted on a scale of 1 to 25,000. Large cities with surroundings areas forming extended urbanised (metropolitan) areas will be dealt with on that scale, requiring joint planning activities by the megacity prime local government and smaller surrounding municipalities.

At the municipal level, urban development planning may be concretised in maps of the scale of 1 to 10,000, with differentiation of urban areas for housing, offices, and production facilities. On this level, land use will not yet be concretised down to single sites of properties except for very large developments. The land use provisions on the municipal level will define the main functions of the respective areas – housing (either alone or in mixture with shopping and services), production facilities (classified according to impact on the neighbourhood and on natural environment), urban green spaces (parks, riversides), and transport infrastructure. The planned population density in housing areas may be defined on that level, too, and the relative share of land area to be covered by buildings. Density parameters such as Floor Area Ratio or Floor Space Index will already be decided upon here, or at the plot level (see below).

Figure 17 shows the principle of overlaying various land uses in urban planning. According to the functions allocated to the areas, transport and other infrastructures have to be decided upon, to avoid frictions, bottlenecks and associated economic losses.

Going down the scale of planning, further details of development will be concretised on

the level of urban districts, or urban quarters, drafted for instance on a scale of 1 to 1,000 or 1 to 500. For each site or property (plot) the kind of land use allowed and the density of uses will be clearly defined, including amongst others the number of storeys, floor area, the heights of the buildings, and its position on the respective sites.

It of course will depend upon ownership and status of the developing entity if decisions are to be made by private investors or by public bodies. There is also always room for changes in the planned land use according to political or economic preferences.

Amongst developing countries, constitutional provisions are diverse with respect to the restrictions on use of private property. This is also true of industrialised countries. While in part of the US landowners are still in a position to decide freely if they wish to build a detached house, a multi-storey apartment building or a commercial facility on their piece of land, in Europe there is a strong tradition of imposing restrictions and guidance for the use of private land. In order to support a sound and structured urban development, private owners have to follow land use regulations laid down in the publicly decided development plans. In practice, private investors often manage to reach a revision of a development plan with respect to the number of storeys or the percentage of office space and housing, but in general the idea of public responsibility for urban development is an established one.

### 8.2 Land use planning in practice

In the *Agenda 21* Document of the Rio Earth Summit in 1992, much importance is attached to local communities. Under the framework of political and administrative responsibilities visualised in the pyramid in Figure 13, local committees and consultation groups involving representatives of both civil society and the business community may be formed to formulate and implement plans.

The Planning Commission, Government of India, has issued the provisions in Table 6 in formulation of the Ninth 5-Year Plan 1998 to 2003. These are based upon work of the Inter-

national Society of City and Regional Planners (ISOCARP). Human and financial resources, as well as the system of balanced responsibility and subsidiarity are reflected in Table 6, recommendations on “New Planning Paradigms”. Table 6 deals particularly with land use planning in India.

An excellent example of urban land use planning, and of the benefits of good planning, is the city of Qingdao, a harbour city in north-eastern China (see Figure 18). Qingdao has a long-standing tradition in land use planning since about 1900, with continuous extensions and improvements. This has resulted in outstanding urban quality. The planning institutions carefully coordinated housing areas and areas for economic development with transport infrastructure improvements. A special focus on rail development minimised negative impact of freight traffic on the urban environment. Special attention has been paid to preserving the urban building heritage, and to maintaining green areas within the urban landscape.

**Table 6: Organisational interface for planned growth in India: Planning responsibilities.**

ISOCARP, modified by Wuppertal Institute, <http://www.unchs.org/unchs/english/urbanpl/asian/asian.htm#4>

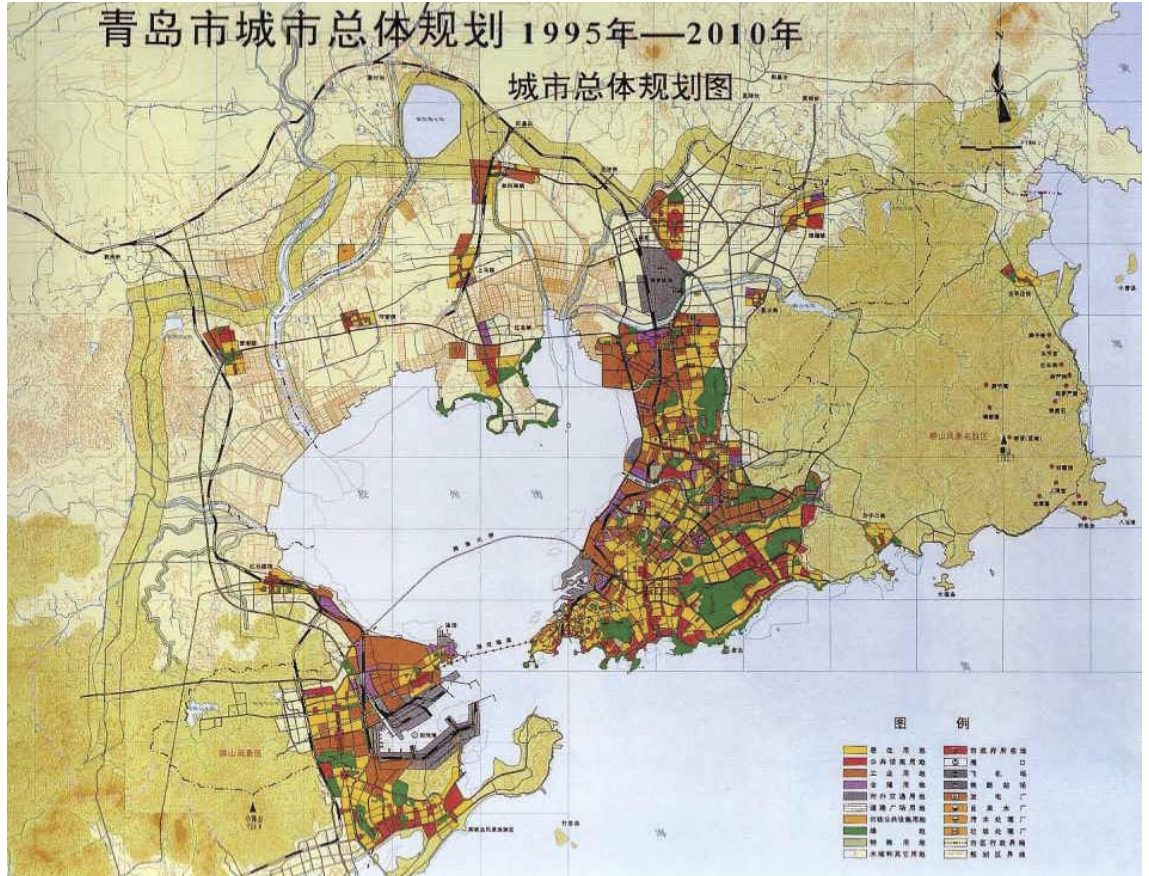
LEVEL	ACTIONS
Central Government	National Policies: Plan funds, bilateral and multilateral targeted programs aid, coordination, etc.
State Government	State Strategies: Industrial policy, population distribution, urban land policy, regional networks, social services, environmental conservation, etc.
District (Regional) Planning Committee	District or Structure Plan: Regional networks, regional social services, regional environmental conservation, allocation of funds, identification of regional projects, intra and inter district coordination, etc.
Metropolitan Planning Committee	Metropolitan Structure Plan: Metropolitan networks and social infrastructure plans, metropolitan fringe coordination plan, local economic perspective plan, identification of metropolitan projects, formulation of public private partnerships, etc.
Local Govt. Municipal Corporations Mun. Councils	Detailed Development Plans: Project formulation, implementation and monitoring, coordination between ward levels (Ward Level Committees are recommended)
Town Panchayats	For municipal corporations generally with population of 0.3 million and above, consolidation of ward level and other plans and projects, prioritising projects, project investment plan, project outlay, project implementation and monitoring, etc.
Ward and Local Level Committees	Local Specific Action Plans: Local project formulation, implementation and monitoring; coordination with local government; input to the development plan.



Fig. 18

*Urban land use plan of Qingdao (China).*

Qingdao Urban Planning Bureau, 1999



**Urban land use plan of Qingdao**

The general layout structure of the city according to the plan is:

- to locate the main urban area along the east coast on the Jiaozhou Bay,
- to locate the auxiliary urban area along the west coast of the Jiaozhou Bay, and
- to promote development along the Jiaozhou coastline to form a “two points and a circle” development structure.

The main and auxiliary urban areas are planned to be in concentration and the other development area along the Jiaozhou Bay is planned to be in decentralisation. Such a “relative concentration and suitable decentralisation” will be the main feature of the general development layout structure.

**8.3 Transport provisions in land use plans**

The planned use of land raises specific requirements and opportunities for the transport system. Access for persons and for goods has to be provided by transport infrastructure and services. Accessibility of a certain property normally will be guaranteed by road, but this will not be acceptable in densely populated areas. Due to the space requirements of private cars, public transport will be required. In the municipal urban development plan a hierarchically structured transport system with roads of certain classes and capacities, as well as mass rapid transit facilities, will be integrated. In the development plan at the district level, further details about size of roads, design of junctions, connections between road and rail, and also sufficient space for pedestrians and cyclists will be provided.

Since the early 1960s, the planning paradigm of urban transport and land use has changed fundamentally. While earlier visions of modern cities had given the private automobile a prominent role in urban transport, leading to

extended highway networks cutting through the urban landscape and serving mainly mono-functional city neighbourhoods, the re-orientation puts more focus on public transport and on the pedestrian (see further Module 1a: *The Role of Transport in Urban Development Policy*). Especially in densely built urban areas, these favourable modes should enjoy preferential treatment in the distribution of road space.

**Pedestrians**

Minimum requirements for size of pedestrian walkways have been developed, related to the volume of pedestrians. A minimum width of two metres has been found necessary. Depending on the number of pedestrians passing, average walking speed, and accepted density of persons per square metre, the required size can be calculated. For example: If there are 5,000 persons passing per hour, and a density of 0.3 persons per square metre is accepted, the width of the pedestrian walkway has to be a minimum 3.5 metres. Densities higher than 0.3 cause uncomfortable walking conditions. Densities of more than 1.0 person per m<sup>2</sup> inhibit mobility.



All pedestrian walkways should be linked together into pedestrian networks. Planning at the district level should aim to develop safe and comfortable conditions for walking, because this makes the city attractive and results in efficient use of scarce land. Police enforcement is necessary to ensure that walkways are not blocked by parking cars (Photo 8).

### Cyclists

Cycling is a highly beneficial transport mode, but often traffic engineers complain about them inhibiting traffic flows. This has led to anti-cycling sentiments in some Chinese cities, e.g. Shanghai (see Photo 9). Bicycle use in urban traffic should often be supported by providing dedicated routes and lanes. (See Module 3d: *Preserving and Expanding the Role of Non-motorised Transport*, for a description of conditions under which segregated bicycle lanes are appropriate.) These also may allow cycling against the main direction in one-way streets (see Beijing example, Photo 10).

### Public transport access

Quality of access to public transport can be rated by average walking time to the next bus stop or rail station. Depending on comfort requirements and on availability of alternatives, a walking distance of between 200 and 350 metres to the next bus or rail stop will be acceptable, amounts to about five minutes walking. Circles of various diameters around public transport stops on city maps will show the quality of access within the district, and indicate deficiencies. Improved permeability of building blocks by providing shortcuts (paths) through the blocks reduces walking distances, and in return allows larger catchment areas.

### Quality of public transport

The quality of public transport service can be described by the number of bus or rail departures per hectare, being a product of the number of routes and of frequency of service. Depending on the density of land use for housing and other purposes, demand for public transport capacity can be calculated using results of household surveys on mobility patterns. If we assume a daily trip rate of 3 to 5 trips per person and a density of 1,000 inhabitants per



**Photo 8**  
*Cars blocking pedestrians (Beijing).*



**Photo 9**  
*Cyclists banned in the daytime (Shanghai).*



**Photo 10**  
*Shortening cycling distances by allowing bicycles to travel counter-flow down one-way streets (Beijing).*

hectare in densely populated housing areas, and a share of public transport of about one quarter of the trip, this would result in a public transport demand of 1,000 per hectare, or – with one bus stop serving about 4 hectares – a daily demand of 4,000 bus passengers on each stop. Given a peak hour share of 10% of the daily demand, 100 passengers per hour will wait at the bus or tram stop.

If we again assume an average trip distance of 10 bus stops, and a capacity of 80 seats for a large bus, more than 12 bus departures per hour are required to serve the demand. This results in a frequency of 5 minutes.

This rough estimate of public transport demand in housing areas does not take into account the weight of special facilities for attracting customers. It is only meant to support the arguments in favour of public transport versus the private car even for accessibility of housing areas. If we go to the Central Business District with many high-rise buildings attracting 10,000 and more commuters or shoppers per hectare, it is obvious that this requires a highly efficient bus system with dedicated bus lanes, or an urban rail system. (See further Module 3a: *Mass Transit Options*.)

### Private motor vehicles

Depending on the distribution of activities with the urban area, different locations evolve as origins and destinations of transport demand. Where average income allows people to own private motor vehicles, the demand will materialise to a certain extent as motor vehicle traffic. Traffic forecast models would be used to calculate the expected flow of private cars and two-wheelers.

As it has been shown in the introductory section, passenger cars occupy much more road space than other modes. In order to improve accessibility for people, access for cars has to be restricted. It also has been argued above that capacity of the urban road network is limited by intersections, rather than by road sections. To avoid heavy congestion up to total gridlock due to overload, it will be necessary to manage traffic demand (see Module 2b: *Mobility Management*). Strategies will include pricing of private car traffic – for instance road pricing or area

pricing – and system improvements for transit, walking and cycling. Car access to certain inner-city areas may be completely banned, allowing pedestrians to walk smoothly along shops and cafes. Depending on the local situation and especially on the size of a pedestrian area, buses may be allowed to enter.

---

*“High acceptance of parking restrictions will be achieved in areas favourably designed for low motorised transport demand, and for efficient public transport.”*

---

### Parking policy

Parking management is a crucial element in traffic demand management. The number of parking places around trip destinations determines the number of cars that will be used. In already built-up urban areas an analysis of traffic flows and acceptable traffic activity will be made, leading to a maximum number of parking lots to be accepted in that respective area. It should be ensured that parking is priced at a level reflecting the value of urban ground. Within the capacity limits decided upon by urban and transport planners, parking garages may be constructed and operated on a commercial basis. Shopping malls and other large attractors of car traffic should be required to charge cost-covering parking fees, too.

For newly developed areas the ratio of floor space to parking space will be specified in the development plans. The crucial question is the modal distribution of demand: in certain locations the share of car travelers may be allowed to reach 5 or 10 percent or even more. This will depend on the local situation, on density, and on the type of land use, as well as on the availability of transport alternatives. Best results and high acceptance of parking restrictions will be achieved in areas favourably designed for low motorised transport demand, and for efficient public transport.



## 9. Land use planning for reduced travel demand

A reduction in travel demand and a shift to more environmentally friendly transport modes can be supported by various measures at different land-use planning levels. Policy and planning principles aiming at supporting sustainable transport modes at the municipal level are described, as well as regional development concepts. Sustainable urban transport and land use planning require a clear idea of the development objectives of the urban and regional area.

### 9.1 Basic principles

Integrated land use and transport planning are essential for environmentally, socially and economically sustainable urban development. Design of urban settlements and choice of locations should aim at:

- reducing the rate of growth of car trips,
- supporting public transportation (for passengers and goods), walking and cycling,
- enhancing healthy conditions for living.

In order to realise sustainable urban development and transport systems which are less damaging to the environment and also effectively serve social and economic development, the following policy principles should be adhered to:

- Major developments should be located in areas well-served by public transport, or public transport provision will be required as part of the development. The agency or company promoting development will provide transport impact assessment and a transport improvement plan.
- As part of the development plan, traffic management schemes should be implemented, including parking policies and traffic restrictions for sensitive areas.
- Planning authorities and developers should ensure safe conditions for pedestrians and cyclists, and put special emphasis on safe routes to schools for children.
- A public transport strategy should be designed and implemented, which makes transit stops easily accessible (see Module 3c: *Bus Regulation and Planning*).
- In order to serve major development areas well by public transport, the urban authori-

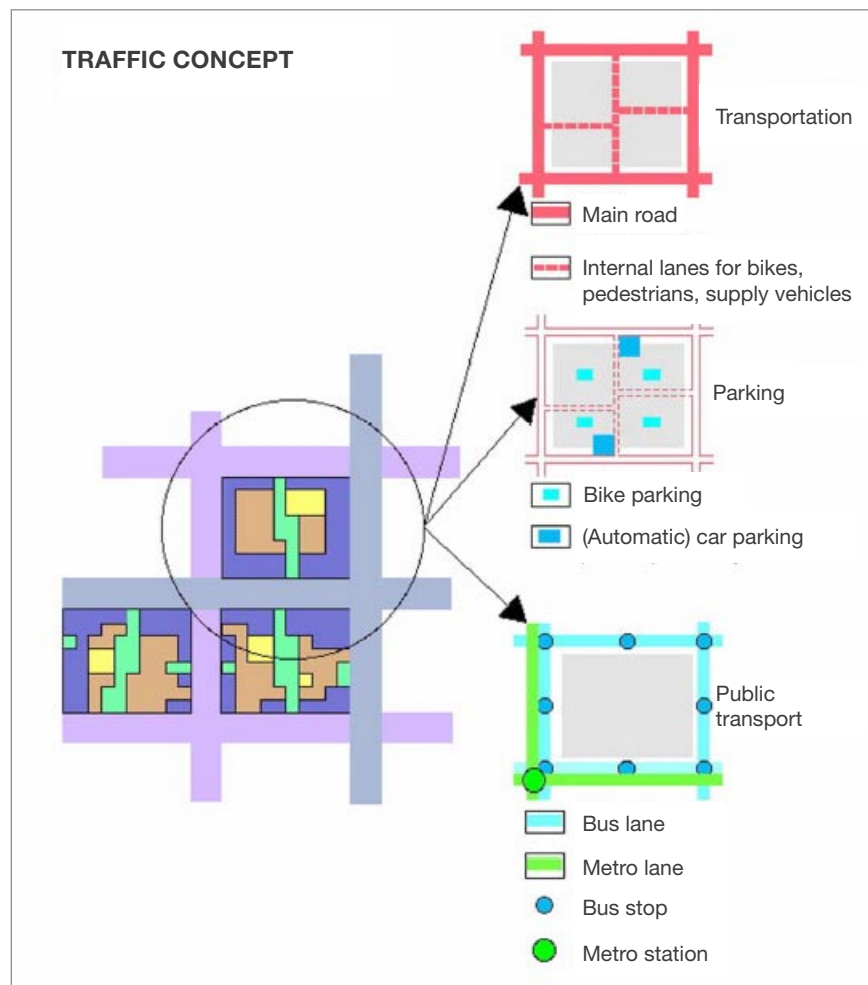
ties responsible for transport planning and for traffic management will introduce dedicated public transport corridors, especially bus lanes.

- New development will be located near existing local high capacity transit routes, terminals, and interchanges.
- New developments attracting a significant amount of goods' transport will be located near existing highway facilities. Network design and traffic management will ensure that new through-traffic does not impinge upon housing areas, and does not interfere with non-motorised travel.

At the level of housing quarters, these principles will materialise in providing good conditions for walking and cycling without hindrance from motorized traffic, good access to public transport lines, and restriction of car access to certain areas. This idea has been called the "environmental area" concept. The principle layout of network grid and restricted access areas is shown in Figure 19.

**Fig. 19**  
*Housing area design for support of sustainable mode choice.*

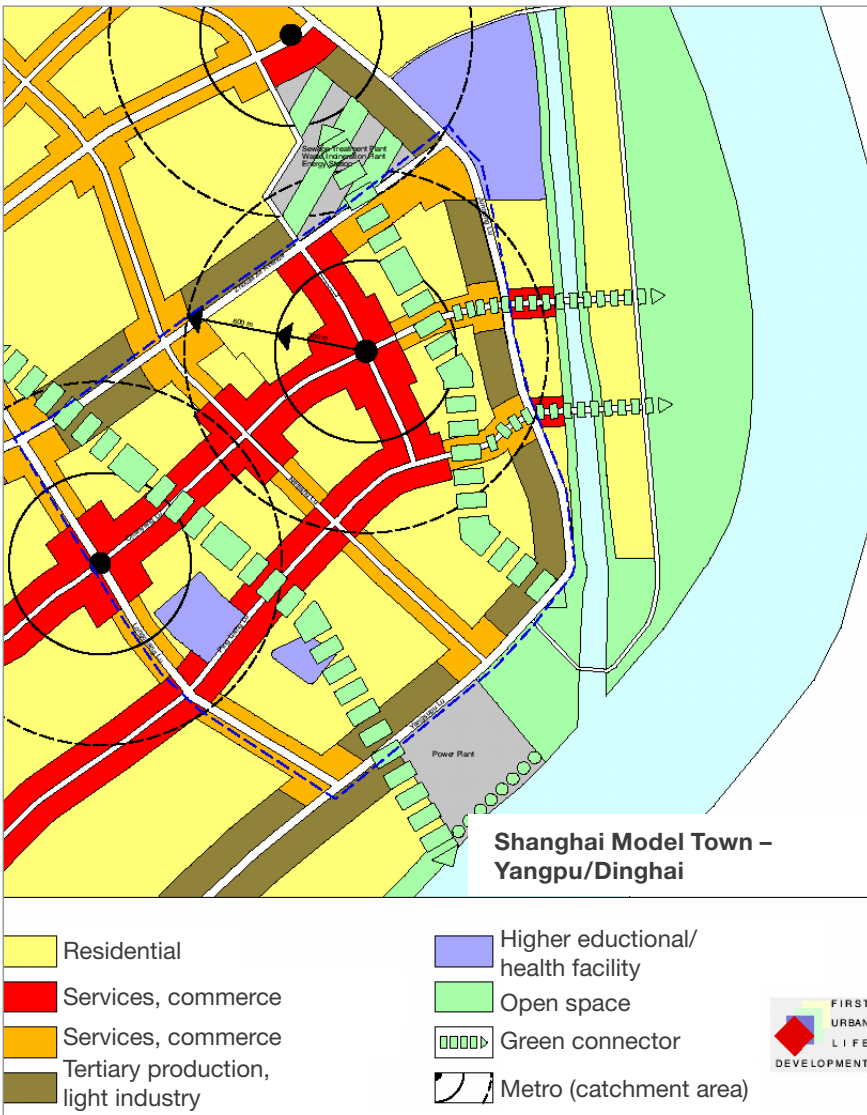
Speer / Kormann, 2001



These principles have been applied to the Shanghai Model Town development of Yangpu/Dinghai. The urban quarter shown in Figure 20 faces basic renewal; it currently is a degraded post-industrial area but nicely located near the Yangtse river, not far from the city centre. The plan introduces green belts and carefully optimized transport infrastructure, and concentrates intensive land uses along major roads. The circles indicate 300 metres and 600 metres walking distance from the Metro stations. The design builds upon preservation of traditional dimensions of urban space without sacrificing urban land to over-sized urban highways.

It is an open question as to whether this design will be realised, and the awarding of World Expo 2010 (see text box) raises more questions about the future of transport and land use planning.

**Fig. 20**  
*Urban design for support of sustainable modes.*  
Speer / Kornmann, 2001  
(simplified for legibility)



## 9.2 Shaping urban land use development for sustainable transport

It is important to assess transport demand caused by the various land uses at a very early stage of urban planning, and assure early integration with transport planning. This sounds rather simple, but is not common in developing cities. The minimum requirement is the establishment of joint working groups at the municipality level, consisting of urban planners from the involved offices, transport planners, and the traffic and public transport management units.

*“The minimum requirement is the establishment of joint working groups at the municipality level.”*



### World Expo 2010 in Shanghai

In December 2002 the Bureau of International Exhibitions decided that Shanghai will host the World Expo in 2010. It is the first time that the exhibition will take place in a developing country and it will bear the motto “Better City, Better Life”.

In the city’s ambitious urban planning blueprint, banks along the Huangpu River will be the centre-piece of renovations, with a 5.4-square-kilometre area reserved for the World Expo 2010 project. The city of Shanghai will invest US \$ 3 billion in the exhibition site and about five to ten-times the amount is expected as additional investments for transport infrastructure and modernisation of the city. The Expo will have major implications for the city and its urban structure. Up to now it is still an open question whether these implications will be mainly positive or negative and whether the Expo 2010 in Shanghai will be simply a ‘prestige’ event or an opportunity for modernisation of the city in the service of its inhabitants.

The concept of a French designer is the winning bid proposal. Key element is a floral bridge linking artificial islands on both sides of Huangpu River. The proposal will be further

### Dutch ABC-Planning

The application of land use planning for reducing transport demand, and for shifting demand to sustainable transport modes requires a clear differentiation of areas according to accessibility with the different transport modes. A pragmatic approach has been developed in the Netherlands with its 15 million inhabitants and the highest population density in Europe (410 inhabitants per square kilometre). National planning authorities have developed integrated land use strategies as guidance for the local level. Cities with more than 100,000 inhabitants are required to prepare land use plans allocating the area into three different categories A, B and C (Figure 21).

A: Locations that are easily accessible to local, regional and national public transport (areas

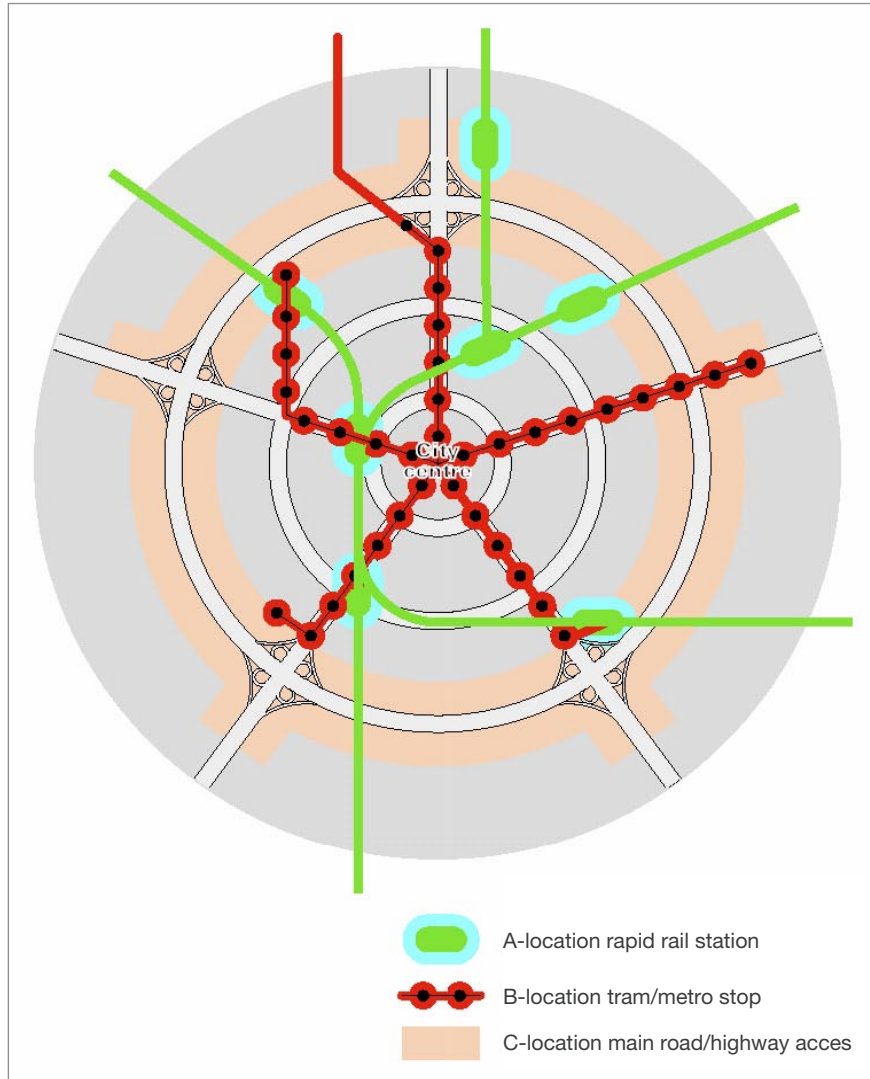
refined and modified (further information see: <http://www.expo2010china.com>)

Referring to current newspaper articles, the Expo site shall be a model example of city renovation. Pollution-generating steelworks, shipmakers, chemical plants, port machinery factories, discarded dock warehouses, shabby huts and apartment buildings that stretch along the river bank will be replaced by magnificent show halls, conference buildings and gardens, restoring the river to its rightful showpiece status. Heavily polluting enterprises are scheduled to either close or move outside the city. An estimated 25,000 people, from 8,500 families, will be relocated to new housing.

In the past Shanghai has suffered from a high urban density combined with few green spaces. According to the deputy director of Shanghai's bidding office, Shanghai intends to transform one third of its land into green spaces.

In addition to the public transportation system currently under construction, other transportation infrastructure will be developed to include the Expo site in Shanghai's mass transit network.

It is estimated that the total number of Chinese and overseas visitors to Shanghai may reach 140 million and this will naturally place significant pressure on the city's transportation system. The 1-hour distribution plan for rail transportation around World Expo is being developed, to ensure the smooth flow of 400,000 visitors daily.



around public transport junctions); share of commuting by car should be under 10 to 20%. In the Netherlands, these localities are typically suitable for offices with a large number of employees and many visitors. The sites have to be within 600 metres of a national or regional railway interchange or within 400 metres of a high quality tram or bus stop; not more than a 10 minute ride from a national railway station and a good connection to park & ride facilities at the outskirts of the city has to be available. Within this category is a further distinction between AI and AII locations. An AI location has to be directly adjacent to a railway station whereas an AII location does not.

B: Locations that are easily accessible both by local and regional public transport and also well accessible by car (areas where high-standard public transport routes cross ring-roads); share

**Fig. 21**  
*ABC location classification of urban areas.*  
Wuppertal Institute



of commuting by car should be under 35%. These locations are characteristically chosen for offices and institutions with a large number of employees, which depend partly on car journeys for professional reasons. Such sites are within 400 metres of a high quality tram or bus stop and no more than a 5 minute ride from a regional railway station. In addition, they have to be within 400 metres of a main road connected to a national highway. BI, BII, and BIII localities have to be defined according to the needs of organisations in the area (e.g. parking facilities are attuned to encourage minimal car use).

C: Locations easily accessible by car (areas along the highways near exits) but with poor public transport supply. In particular, such sites are suitable for car-dependent companies like haulers, couriers or other industries. These sites are within 1000 metres of a direct connection to a national highway. C locations are normally situated in the outskirts of metropolitan areas. (<http://www.epe.be/workbooks/tcui/example12.html>)

In simple terms, the three location categories can also be characterised as suitable for:

- A: population-based activities
- B: mixed activities
- C: freight-based activities.

**Table 7: ABC scheme: ratio of parking spaces to gross floor space in relation to function and locality.**

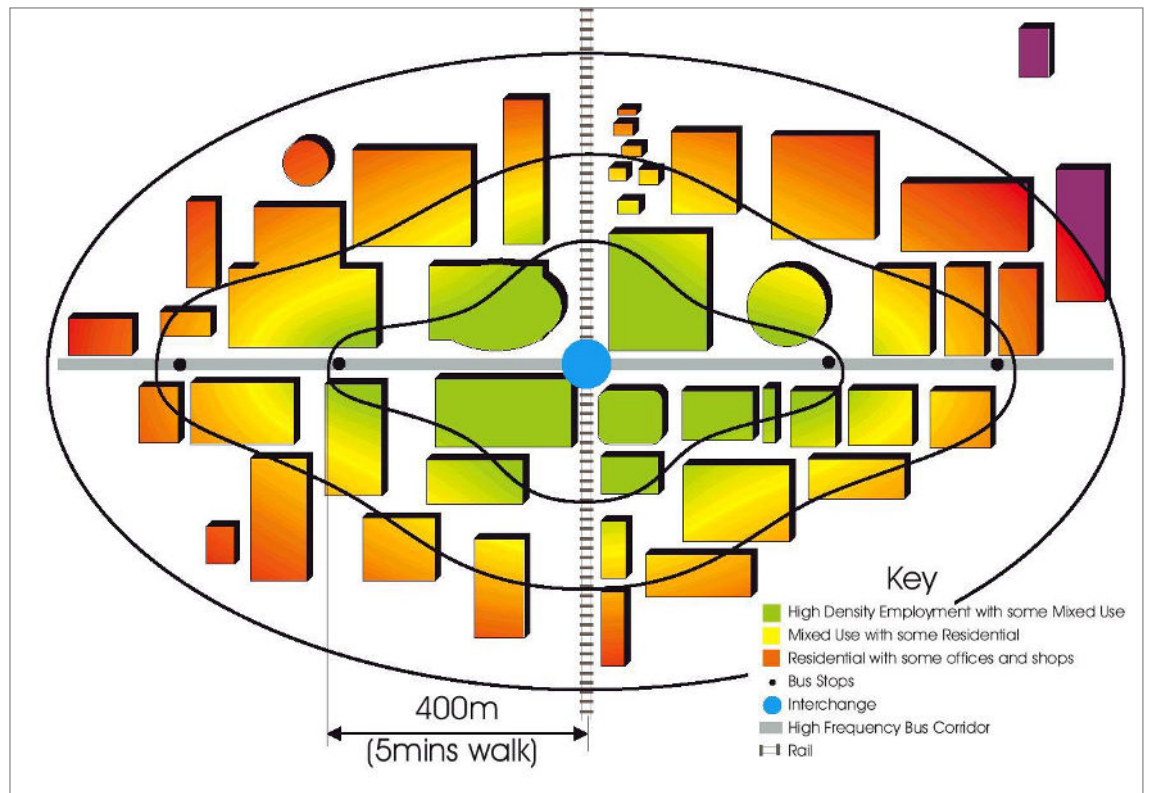
<http://www.eaue.de/winiwd/131.htm>

Locality	Minimum ratio	Maximum ratio
A1 (offices)	1: 250	1: 250
All (offices)	1: 175	1: 250
B (offices, business)	1: 125	1: 90
C (business)	1: 90	1: 60
A1/All (advanced education)	1: 250	1: 250
B/C (advanced education)	1: 145	1: 145
A1/All (shopping centres)	1: 90	1: 40
B/C (shopping centres)	1: 65	1: 30

As the availability of parking space is a vital aspect in the reduction of car use in a certain area, the ABC categories are linked to a fixed number of car parks per classified area. The ratios in Table 7 apply in the Netherlands.

The locations are matched with requirements of various businesses and services. Each business is given a mobility profile according to number of employees and visitors, the dependence on car traffic and freight traffic. Shops are preferably located in A-areas, never in C-areas. Offices

**Fig. 22**  
*Key site concept, ABC policy.*  
Buchanan, 2001



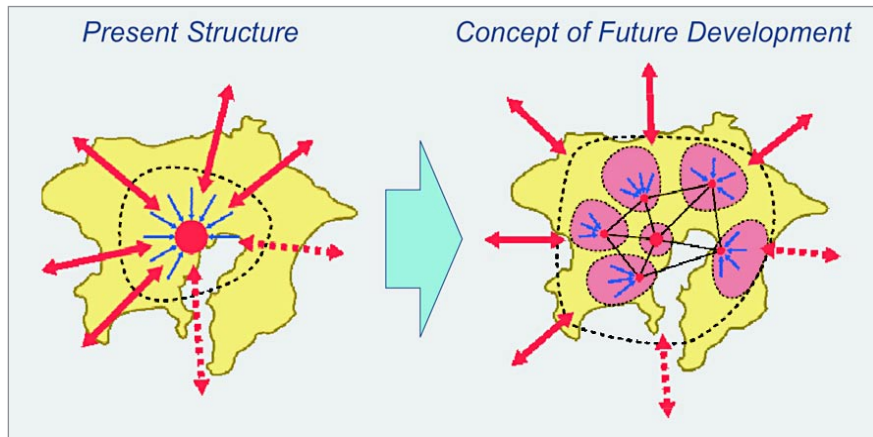
are located in A- and B-areas, while C-areas should only be used for transport facilities, or land-intensive activities. The ABC system integrates a series of standards concerning density of employees per square metre, and parking places per employee. For example, concerning parking standards: In A-localities of large cities the maximum number is ten parking spaces per hundred employees, and in B-localities twenty per hundred employees.

The ABC system is a strict spatial strategy for a good localisation of different activities, based upon comprehensive analysis of the relation between quality of location and transport demand.

In the Dutch ABC concept, locations classified with “A” will be the key development areas within an urbanised landscape. But also within the city centres and sub-centres there are differences with respect to accessibility. Figure 22 illustrates this by indicating best accessibility with public transport in green color. The best location for facilities attracting large numbers of travelers is within walking distance around a rail station also served by major bus routes. Increasing distances from that spot will be less attractive for transit passengers, and travelers will increasingly tend to use private cars and taxis.

This kind of land use differentiation can be the basis for dedicated policies, including tax incentives for commercial investors, and public investment priorities.

The ABC scheme and the key site concept should not be misinterpreted with respect to the general urban development paradigm. These concepts are not meant to support only central development. Within the urban area many traffic problems result from too concentrated development in the central district. Especially when housing spreads in the outskirts of the cities, and workplaces as well as shopping facilities located in the city centres attract travelers, congestion and emission hot spots occur. Private households and business investors then tend to move outwards, which initiates the “vicious cycle” of dispersed sprawl development and traffic increase explained in section 1.2 (see Figure 1 “traffic spiral”). The more healthy way to cope with this situation is the formation of sub-centres within the city, as visualised in Figure 23.



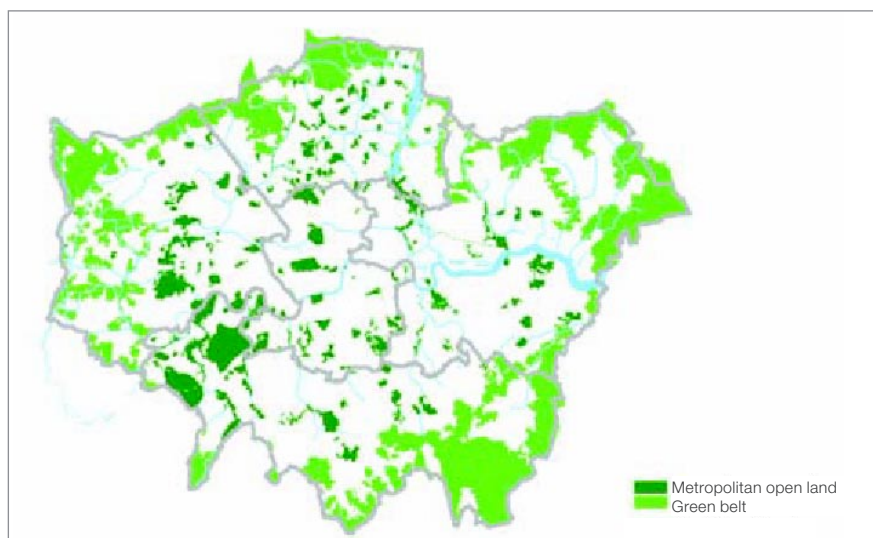
**Fig. 23**  
*Core city development: Urban decentralisation into sub-centres.*  
Mori, 2000

The objective of that kind of urban development is to reduce traffic pressure on the roads leading to the main centre, and to keep private household and commercial investors within the urban boundaries. Sub-centres can be served well by public transport; they sometimes will materialise around existing mass rapid transit stations. Land use plans and public investments can lead the development, in close coordination with modernisation of public transport networks. Development activities in sub-centres will lead to more homogenous distribution of activities, thus reducing average trip distances and mitigating traffic increases. Such development is a necessary step in order to maintain a compact urban form.

*“Connecting parks and small green areas ... form chains of green”*

This kind of centralised decentralisation within the urban area may be hindered by former

**Fig. 24**  
*Growth boundary and green belt areas in London.*  
City of London: Towards the London Plan, Initial Proposals for the Mayors Spatial Development Strategy, May 2001





**Fig. 25**

*Leap-frog development in spite of growth boundary: Population density in radial distance from the city centre.*

Reform for Urban-Rural Continuum in Planning Controls, Sang-Chuel Choe (Seoul National University) <http://up.t.u-tokyo.ac.jp/SUR/papers/Choe.pdf> accessed July 10, 2002



industrial sites (brown-fields), often located on contaminated soils. Urban land management institutions are needed to buy and clean up these areas, before they can be marketed for construction of housing and office buildings, and for clean manufacturing industries compatible with mixed development. Redevelopment of brown-fields also provides the chance to increase the share of urban green areas by creating open land areas, parks and green belts. Figure 24 demonstrates the distribution of green urban areas within a large city (here: London). The ecological functions are supported by connecting parks and small green areas to form chains of green. The green map of London also shows the green belt around the city, acting as a barrier against sprawl.

The planning instrument to avoid urban sprawl spreading out from the city into the rural surroundings is the “urban boundary” concept. By banning development beyond a certain line around the city, and preserving it for agriculture or natural habitats, the urban investments will be directed either with the urban area – or will focus on areas beyond the boundaries, preferably into clearly defined centres, forming satellite cities. With increasing population of an urban region, both the density within the city and in the surrounding areas will increase.

Figure 25 explains the development in radial distance to a city centre after an urban boundary for development has been implemented. It refers to the City of Seoul, which already in the late 1960s introduced a green belt barrier against disperse sprawl development.

### 9.3 Regional development for sustainable transport

Population growth of large cities has been changing the regional land use structure: Built-up areas are increasing beyond the traditional boundaries; metropolitan areas more and more shift into conurbations, which include previously independent municipalities. There are different strategies to deal with this administrative challenge. As discussed previously, one approach is to redesign urban boundaries in a way that there is a unified urban administrative responsibility covering the whole conurbation. Another is the establishment of a regional

administrative level, such as a metropolitan area administration under which the municipalities cooperate. Division of responsibilities between the municipal level and the regional level has to be decided upon. Major land use responsibilities will be shifted towards the upper level.

There is a natural competition between the various municipalities, or districts of the enlarged city, with respect to public and private investments. Politicians and planners responsible for peripheral locations with less development momentum will argue for more development, citing cheaper land and labour. Because sustainable transport requires concentrated and mixed-use development, land use planning inevitably will face controversial positions between interests located in centres, and in peripheral locations. It is necessary to implement concepts to develop remote locations, too, without compromising sustainability principles.

In the scope of regional development, the principle of decentralised concentration can be applied, similar to the concept described in the preceding section. It aims for concentrated development of urban and suburban areas around selected locations, which are chosen under consideration of regional-planning aspects and with a well-developed public transport infrastructure. New building areas should be allocated around

#### Yokohama's growth model

The City of Yokohama has based its urban area growth on radial rail lines since the 1960s, supporting preferred development near stations (see Figure 26). The responsible planners of the municipality give the transport planning objectives for a high share of public transport as follows (Municipality of Yokohama 2000):

- Taking less than 15 minutes (by walking, or walking and bus) to the nearest station
- Taking less than 30 minutes to Yokohama city centre.

This mass transit-supported decentralised centralisation can serve as a model for sustainable urban growth. A different strategy but also a convincing success was achieved by the City of Curitiba (Brazil), which closely linked the establishment of a highly efficient Bus Rapid Transit system with land-use planning.

nuclei formed by transit stations, and should be kept compact in order to enable accessibility of passengers and of goods by rail or bus, and minimise internal trip distances. Decentralised concentration, in combination with a sound mixture of functions, with complementary workplaces and other infrastructure facilities, will develop the region in the form of pearls on a chain formed by transit lines. In an even larger geographical scale, this principle leads to satellite cities around the metropolitan areas, with minimum population of some hundred thousand people. Size of the satellite cities will depend on local circumstances. The Beijing Master Plan mentions a population range from 150,000 to 400,000 (“Sixth Major Cities Summit, Beijing, 2000; A Brief Introduction to the Beijing Master Plan 1991 – 2010”).

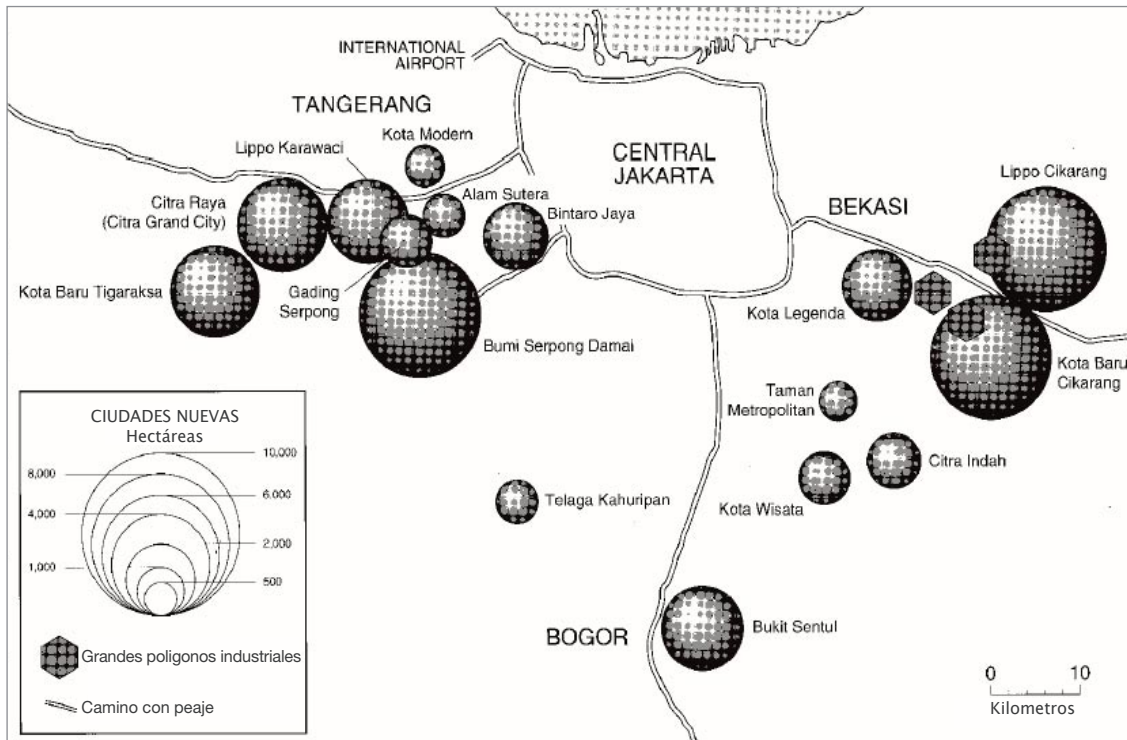
The green belt or urban boundaries principle described above in Section 9.2 limits geographical growth of a city but, as can be seen in Figure 19, is of course not a barrier for growth outside the belt. Population and market pressure will result in increasing settlement activities outside which either can be channeled into centres, or result in sprawl if no strict regional land use schemes are implemented. Moving from the main urban area into the surroundings then requires a leap-frog type of growth. From an environmental point of view it is desirable to create concentrated development clusters; either around existing villages or small cities, or anew from scratch. In the US a recent trend has been identified of such cities growing around important highway junctions, researchers naming them “edge cities”.

In fast-growing Asian countries like China, the creation of satellite cities is not market-driven, as with the edge-cities in the US, but based on public planning and investments. They have been conceptualised as “relief cities” at a clear distance to the existing megacities, in order to take growth pressure off the megacities. The basic idea behind them is to establish self-supporting cities which of course benefit from relative proximity to the megacities, but are far enough away to discourage daily commuting. Each of the relief cities has some 100,000 inhabitants, providing all necessary functions for households and businesses.

Satellite cities can be defined as settlements functionally closely related to the urban large units, while relief cities have a higher potential for development independent of the megacity. Satellite cities are to a certain extent still functionally linked to the major city, but this does not refer to everyday-mobility of the population. Businesses take advantage of the nearby agglomeration but enjoy lower land prices, better environmental quality and less congestion. In China, the increase in the number of small cities (less than 200,000 inhabitants) is impressive (Huapu 2002) and serves as relief for the large ones. The basic idea and purpose of satellite cities, is to limit the spatial spreading of the major city, avoid urban sprawl and thus maintain the functioning of the metropolitan areas.

Creation of a satellite-cities system in Indonesia in the capital region of Jakarta was mainly market-driven, and promoted by large private investors as well as a conducive policy environment (Dick & Rimmer, 1998). Jakarta is becoming chronically polluted and congested, and growth has integrated neighbouring cities into the mega-region of Jabotabek. Jakarta’s development raises concerns with respect to resulting transport demand of the spatial changes, because the new developments (see Figure 26) are designed according to North American, car-oriented models.

All main new town projects and industrial estates have been developed along the toll roads feeding into the city’s outer ring road (see Figure 26). In 1989, a new town project Bumi Serpong Damai, which covers an area of 6,000 hectares of land to the west of Jakarta, commenced construction. Firstly a golf course and a gated community were developed, and as the density increased, other facilities such as schools, offices and shopping malls were added. Ultimately, this project will include a 300-hectare CBD and a 200-hectare business park with a projected employment of 140,000 people. Another example is the satellite town Lippo Karawaci (2360 hectares) in West Jakarta. By 1997, Lippo Karawaci had a CBD with multiple office towers, a 100,000 m<sup>2</sup> shopping mall, two condominium towers, a 328-bed international hospital, a private school and country club and five-star international hotel.



**Fig. 26**  
*Satellite cities in Jakarta: New towns and industrial estates approved and under construction.*  
 Dick & Rimmer, 1998. Note: Jakarta Waterfront City, Teluk Naga, Bukit Indah City and Bukit Jonggol Asri are not shown

**Photo 11**  
*Shanghai/Pudong development vision.*  
 Municipality of Shanghai

The recent concept of land use development in Jakarta is to combine the development of satellite cities and extension of Jakarta with the intensification of development within Jakarta. The latter is to be achieved by reclamation of the waterfront and by allowing a higher intensity of use by, for example, allowing developers to build higher than the limit of 32 storeys previously defined. The intensification of development in these zones is compatible with the plan in transportation terms only if high and effective levels of service by public transport can be achieved. Without an adequate transit system and demand management measures, powerful trends towards dispersion of activity are likely to occur, undermining recent investments and engendering urban sprawl.

A prominent example of new development extending the city's previous boundaries but with problematic transport consequences is Pudong, near Shanghai. The urban design is based upon broad roads and arteries, as Photo 11 shows. The picture was taken from an official planning brochure, and reflects a US-style of urban development, which does not build upon the transit-based best practices of land use and transport planning.





## 10.A checklist for land use and transport plans

### 10.1 New developments

<b>Task 1.1 Decentralised concentration</b>
Are new urban development areas located along attractive public transport routes?
Are new urban development areas located at places with existing amenities, e.g. local shopping and service facilities, and where jobs are available?
Does planning guarantee a balanced use of public transport routes (in both directions)?

<b>Task 1.2 Decentralised facilities</b>
Are shops for daily needs, sports facilities, kindergarten, schools, doctors' practices, administrative and leisure facilities planned as decentralised as possible?
Are facilities accessible on foot and by bike (starting from residential areas)?
Are these facilities mainly located at the centre of the built-up area?
Has an excessive concentration of utilities, leisure facilities and workplaces been avoided?

### 10.2 Public transport and land use

<b>Task 2.1 Increase use of public transport</b>
Is the designation of new urban areas or the densification of existing ones aligned to the existing or planned capacity of public transport?
Are the new centres of urban areas located within the catchment area of stations of the local and regional transit routes?
Are busy central facilities easily accessible by public transport, on foot and by bike by a large number of people? Are the different facilities close to each other to enable the combining of trips with environmentally sound transport modes?
Is a cost-efficient development of public transport infrastructure possible?
■ using an existing route or stop
■ moving an existing stop
■ setting-up of an additional stop on an existing route
■ extending an existing route
Can important destinations of daily life be reached by public transport at short distances during and out of rush hours?
Is the option kept open to improve mass rapid transit operation by reserving additional areas necessary for extending existing right of way?

<b>Task 2.2 Access to Stops</b>
Is there an easy and safe access to the stops?
Are there any detours? If so, can they be reduced?
Are there under- or overpasses? If so, can they be replaced by ground-level crossings?
Is traffic safety guaranteed?
Is social safety during day- and nighttime guaranteed?
What is the walking distance (minimum and maximum) to stops?

<b>Task 2.3 Public transport in traffic</b>
Are obstructions of public transport caused by parked or flowing motorised private transport minimised?
Are measures executed to separate public transport and motorised traffic, e.g. special bus lanes or traffic lights?
Are obstructions of public transport minimised by architectural traffic calming measures?
Are special solutions to avoid detours by public transport needed, which cannot be used by other motorised traffic (e.g. bus-gates which allow pedestrians bikers and public transport to pass areas restricted for the motorised private transport)?

### 10.3 Urban development

<b>Task 3.1 Location of new urban areas</b>
Are areas for new/ intensified utilisations located at centreline of settlement, within built-up sites, on the outskirts of town or outside?
Are different facilities (e.g. workplaces, shops for daily needs, kindergarten, schools, sport facilities) in the new urban areas or neighboring districts accessible on foot or by bike?
Are those facilities located in the main part of the built-up area?
Has urban sprawl been avoided?

<b>Task 3.2 Minimisation of space in new urban areas</b>
Has priority been given to infill development i.e. closing of gaps between buildings, use of remaining areas not yet designated (e.g. industrial waste land, conversion areas) or the use of vacant buildings?
Is there an appropriate limitation to space requirements (residential or commercial areas per capita)?
Is there an acceptable densification of residential/ industrial or mixed areas?
Has densification in the catchment area of stops been catered with high-class public transport?

<b>Task 3.3 Spatial mixture of utilisations</b>
Are the utilisations balanced (e.g. living and working) or is there a surplus or shortage (e.g. of workplaces or shops)?
Does a mixture of utilisation exist on a reasonable level of scale (floor, building, block, district, and town)?
Have areas for amenities, service and trade been at least partly designated at the ground floor level in residential areas?
Is a socially balanced mixture expected in new/densified residential areas?

### 10.4 Motorised private traffic

<b>Task 4.1 Hindrance caused by parked vehicles</b>
Are hindrance to flowing traffic, especially pedestrian and bicycle traffic as well as public transport, minimised?
Is hindrance to non-traffic related utilisations (staying, playing, recreation, green areas) and to neighbouring districts minimised during day- and night-time?

<b>Task 4.2 Construction of parking facilities</b>
Are public transport stops located just as advantageously to housing as parking areas/garages?
Are conflicts between pedestrian and bicycle traffic and parking vehicles at the entrances and exits and in the parking areas minimised?
Are entrances and exits areas avoided where tailback from intersections is possible?
Are conflicts between moving and parked traffic minimised?

### 10.5 Freight transport

<b>Task 5.1 Environmentally compatible infrastructure</b>
Are new transport-intensive utilisations (e.g. larger commercial or industrial zones) and rail-related volumes of freight planned with a railway siding or close to railway facilities?
Do freight centres for railway/ waterway/ road feature a good road connection?

<b>Task 5.2 Designation of commercial zones</b>
Is public transport infrastructure developed in a cost-effective way?
Have suitable areas been reserved for locating logistics facilities (e.g. city/ regional logistics, freight centres)?

## 11. Resources

### 11.1 Internet resources

- Asian Development Bank (ADB), *Transport Planning, Demand Management, and Air Quality*, 26-27 Feb. 2001, Manila, Philippines, [http://www.adb.org/Documents/Events/2002/RETA5937/Manila/transport\\_downloads.asp](http://www.adb.org/Documents/Events/2002/RETA5937/Manila/transport_downloads.asp)
- COST-Transport 332: *Transport and Land-use Policies*, Final Report of the Action Manuscript completed in December 2000, <ftp://ftp.cordis.lu/pub/cost-transport/docs/332-en.pdf>
- Institute for Transportation and Development Policy (ITDP), e-Bulletin “Sustainable Transport”, <http://itdp.org/Ste/index.html#asia>
- Jonkhof, J. (without year): *The Netherlands: The ABC Location Policy*, <http://www.epe.be/workbooks/tcui/example12.html>
- SUSTRAN Network, Sustainable Transport Action Network for Asia and the Pacific, <http://www.geocities.com/RainForest/Canopy/2853>
- Transland Website, (Integration of Transport and Land Use Planning) of the 4<sup>th</sup> RTD Framework Programme of the European Commission, <http://www.inro.tno.nl/transland/>
- U.S. Federal Highway Administration/Office of Planning and Environment, Selected References Evaluating the Relationships Between Travel and Land Use (Status of 1999), <http://www.fhwa.dot.gov/tcsp/selrefev.html>
- UN-Economic and Social Commission for Asia and the Pacific (UNESCAP), *Municipal Land Management in Asia: A Comparative Study*, [http://www.unescap.org/huset/m\\_land](http://www.unescap.org/huset/m_land)
- UN-Habitat, United Nations Human Settlement Programme, <http://www.unchs.org>
- University of North Carolina at Charlotte, <http://www.uncc.edu/hscampbe/landuse/b-models/B-3mods.html>
- University of Utrecht: Monitoring Trends in Urban Growth using SPOT Imagery. The Case of Ouagadougou, Burkina Faso, <http://www.geog.uu.nl/fg/UrbanGrowth>

- Urban Transport Strategy Review Consultations, South Asia and East Asia, Yokohama, Japan, December 11 - 13, 2000, <http://www.worldbank.org/transport/utsr/yokohama/agendayo.htm>
- Victoria Transport Policy Institute (VTPI), *On-Line Encyclopedia Transport Demand Management*, <http://www.vtpi.org/tdm/tdm12.htm>
- Victoria Transport Policy Institute (VTPI): *Transportation Cost and Benefit Analysis – Land Use Impacts*, <http://vtpi.org/tca/tca0514.pdf>
- World Bank Group, Urban Development, Cities in Transition, Urban and Local Government Strategy, <http://wbi018.worldbank.org/External/Urban/UrbanDev.nsf>
- World Resource Institute (without year): *Squatter Housing as a Percent of Total Housing Stock, Selected Cities*, [http://www.wri.org/wri/wr-96-97/up\\_f3.gif](http://www.wri.org/wri/wr-96-97/up_f3.gif)
- Chin, Nancy (2002): *Unearthing the Roots of Urban Sprawl: A Critical Analysis of Form, Function and Methodology*, Center for Advanced Spatial Analysis Working series, Centre for Advanced Spatial Analysis; University College London, [http://www.casa.ucl.ac.uk/working\\_papers/paper47.pdf](http://www.casa.ucl.ac.uk/working_papers/paper47.pdf), Date: March 2002 Paper 47
- City of London (2001): *Towards the London Plan, Initial Proposal for the Mayors Spatial Development Strategy*
- Choe, Sang-Chuel (without year): *Reform for Urban-Rural Continuum in Planning Controls* (<http://up.t.u-tokyo.ac.jp/SUR/papers/Choe.pdf>)
- Dick, H. W. / Rimmer, P. J. (1998): *Beyond the Third World City: The New Urban Geography of South-east Asia*, *Urban Studies*, Vol. 35, No. 12, 2303± 2321, 1998
- Ebels, Enno (without year): *Utrecht: “ABC” Planning as a planning instrument in urban transport policy* (<http://www.eaue.de/winuwd/131.htm>)

## 11.2 Bibliography

- Barter, A. Rahman Paul; Raad, Tamim (2000): *Taking Steps: A Community Action Guide to People-Centred, Equitable and Sustainable Urban Transport*; Sustainable Transport Action Network for Asia and the Pacific (SUSTRAN Network), <http://www.geocities.com/RainForest/Canopy/2853/actionguide/Outline.htm>
- Braendli, Heinrich (2001): *Integrating Road and Rail Networks*, lecture at workshop on Integrated Transportation and Environment Protection, Paper Collection, Transport Working Group, China Council for International Cooperation on Environment and Development
- Buchanan, Colin et al. (2001): *Key Site Appraisal Methodology for Development Planning*; Final Report, Scottish Executive, available via <http://195.92.250.59/library3/planning/ksap-00.asp>
- CCICED/TWG (1999): *Urban Transport and Environment Workshop*, Beijing
- Cervero, Robert (2000): *Transport and Land Use: Key Issues in Metropolitan Planning and Smart Growth*; University of California Berkeley Transportation Center, <http://www.uctc.net/papers/436.pdf>
- Cervero, Robert (2001): *Road Expansion, Urban Growth, and Induced Travel: A Path Analysis*, University of California, Berkeley <http://www.uctc.net/papers/520.pdf>
- Gilbert, Alan (ed.) (1996): *The Mega-City in Latin America*; UN University Press, Tokyo; accessible via <http://www.unu.edu/unupress/unupbooks/uu23me/uu23me00.htm>
- Gorham, Roger (1998): *Land-Use Planning and Sustainable Urban Travel – Overcoming Barriers to Effective Co-ordination*, OECD-ECMT Workshop on land-use for Sustainable Urban Transport: Implementing Change, Linz, Austria
- Gorham, Roger (2002): *Traffic Flow Improvements: Taking Induced Travel Into Account*, ADB Regional Workshop on Transport Planning, Demand Management and Air Quality February 27, 2002 (PowerPoint Presentation available via [http://www.adb.org/Documents/Events/2002/RETA5937/Manila/transport\\_downloads.asp](http://www.adb.org/Documents/Events/2002/RETA5937/Manila/transport_downloads.asp))
- GTZ (ed.) (2001): *Efforts toward sustainable urban transport in Surabaya, Indonesia – An Integrated Approach*, GTZ Sustainable Urban Transport Project, <http://www.sutp.org>, <http://www.sutp.org/docs/policye.pdf>
- Huapu, Lu (2002): *Review of the Urban Growth over the Past Twenty Years & Prospects for the Next 2 or 3 Decades*, Institute of Transportation Engineering, Tsinghua University 2002-1-16
- Kenworthy, Jeff; Laube, Felix et al. (1999): *An International Sourcebook of Automobile Dependence in Cities 1960-1990*; updated edition, Boulder



- Kenworthy, Jeff; Laube, Felix (2002): Urban Transport Patterns in a Global Sample of Cities and their Linkages to Transport Infrastructure, Land Use, Economics and Environment; Institute for Sustainability and Technology Policy, Perth, <http://www.wmrc.com/businessbriefing/pdf/infrastructure2001/reference/29.pdf> accessed July 17, 2002
- Martens, M. J.; v. Griethuysen, S. (1999): The ABC Location Policy in the Netherlands, The Right Business at the Right Place, TNO Inro, [http://www.inro.tno.nl/transland/cases\\_prio/01-ABCpolicy.PDF](http://www.inro.tno.nl/transland/cases_prio/01-ABCpolicy.PDF) accessed July 22, 2002
- McNulty, Kelvin (2002): The Impact of the Mass Use of Motor Cars on Lifestyle and Land Use; <http://www.gcircle.co.uk/glastonbury/philosophy/lut.html> accessed 07.03.2002
- Metge, Hubert (2000): Relationship between Urban Land Use Planning, Land Markets, Transport Provisions and the Welfare of the Poor – Case Study of Cairo (Final Report – CA-TRAM, France) World Bank Urban Transport Strategy Review
- Meurs; Haaijer (2001): Spatial Structure and Mobility, Transportation Research, Part D, Transport and Environment, Vol. 6 (6): 429-446
- Mori, Hideki (2000): Japanese Experiences on Transport/Land use Integration; PowerPoint presentation prepared for ASIAN Consultation Workshop of Urban Transport Sectors Strategy Review, accessible via <http://www.worldbank.org/transport/utsr/yokohama/agendayo.htm>
- Newton, P. (1999): Transport, Clean Air and Design Options for Cities of the Future; Building Innovation and Construction Technology Number 8, August 1999; [http://www.dbce.csiro.au/innovation/1999-08/pdf/innovation\\_cities.pdf](http://www.dbce.csiro.au/innovation/1999-08/pdf/innovation_cities.pdf) accessed July 17, 2002).
- Qingdao Urban Planning Bureau (1999): Qingdao develops with new era. Urban overall plan of Qingdao
- Ranhagen, Ulf; Trobeck, Sara (1998): Physical Planning and Sustainable Urban Transport. A Comparative Analysis of Four International Cities. FFNS Arkitekter Sida, December 1998
- Rat, Hans (2001): Urban Growth versus Sustainable Mobility; UITP Statement, FIDC 2001 Annual Conference, <http://www.fidic.org/conference/2001/talks/monday/rat/rat.pdf>
- Replogle, Michael (1992/1994): Non-Motorized vehicles in Asia: Strategies for Management; Center for Renewable Energy and Sustainable Technology (CREST), <http://solstice.crest.org/planning/nmv-mgmt-asia>
- Rodrigue, J-P et al. (2002) Transport Geography on the Web, Hofstra University, Department of Economics & Geography, <http://people.hofstra.edu/geotrans>
- Schafer, A.; Victor, D. (2000): The Future Mobility of the World Population, Transportation Research A, 34 (3): 171-205
- Sheehan, Molly O'Meara (2001): City Limits: Putting the Brakes on Sprawl; WorldWatch Paper 156, Washington
- Sixth Major Cities Summit Beijing (2000): A brief introduction to the Beijing Master Plan (1991-2010) <http://202.84.11.103/docs/bjfc/2000-08-30/30975.shtml>
- Southworth, Frank (1995): A Technical Review of Urban Land Use—transportation Models as Tools for Evaluating Vehicle Travel Reduction Strategies; for US-DOE, National Transport Library, US Bureau of Transportation Statistics ORNL-6881 <http://ntl.bts.gov/DOCS/ornl.html>
- Speer, Albert; Kornmann, Stefan (2001): Planen und Bauen über Grenzen, Informationen zur Raumentwicklung, Heft 4/5.2001
- UNCHS (ed.) (2002), Reassessment of Urban Planning and Development Regulations in Asian Cities, <http://unchs.org/unchs/english/urban/asian/asian.htm#4> accessed 06.05.2002
- Wegener, Michael, Fürst, Franz (1999): Land-Use Transport Interaction: State of the Art, Deliverable 2a of the Project TRANSLAND (Integration of Transport and Land Use Planning) of the 4<sup>th</sup> RTD Framework Programme of the European Commission, Dortmund.









Deutsche Gesellschaft für  
Technische Zusammenarbeit (GTZ) GmbH

Dag-Hammarskjold-Weg 1-5  
P. O. Box 5180  
D - 65726 Eschborn  
Germany  
Telefon +49-61 96-79-1357  
Telefax +49-61 96-79-7194  
Internet: <http://www.gtz.de>

commissioned by



Bundesministerium für  
wirtschaftliche Zusammenarbeit  
und Entwicklung

